

Hybrid MPI+OpenMP Parallel MD

Aiichiro Nakano

*Collaboratory for Advanced Computing & Simulations
Department of Computer Science
Department of Physics & Astronomy
Department of Quantitative & Computational Biology
University of Southern California*

Email: anakano@usc.edu

Objective: Hands-on experience in default programming language (MPI+OpenMP) for hybrid parallel computing on a cluster of multicore computing nodes

Alternative to MPI-only: million ssh's & management of million processes by MPI daemon

<https://aiichironakano.github.io/cs596/Kunaseth-HTM-PDSEC13.pdf>

MPI+X: <https://www.hpcwire.com/2014/07/16/compiler-mpix>

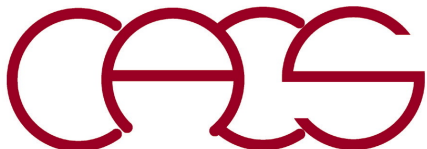

Hybrid MPI+OpenMP Programming

Each MPI process spawns multiple OpenMP threads

d05-10

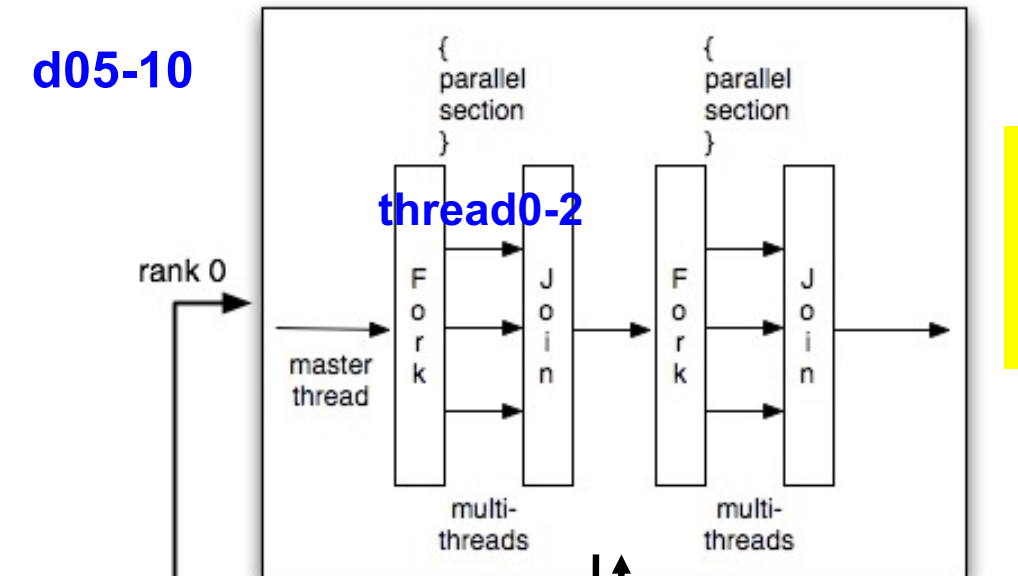

mpirun

rank 0

MPI_Send/MPI_Recv

rank 1

d05-11

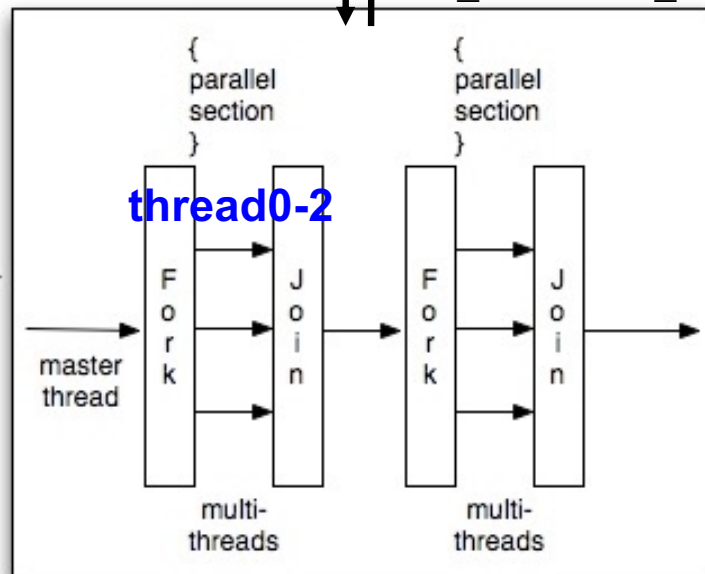

In a Slurm script:

```
mpirun -n 2
```

In the code:

```
omp_set_num_threads(3);
```

- MPI processes communicate by sending/receiving messages
- OpenMP threads communicate by writing to/reading from shared variables

MPI+OpenMP Calculation of π

- **Spatial decomposition:** Each MPI process integrates over a range of width $1/nproc$, as a discrete sum of `nbin` bins each of width `step`
- **Interleaving:** Within each MPI process, `nthreads` OpenMP threads perform part of the sum as in `omp_pi.c`

$$\pi = \int_0^1 \frac{4}{1+x^2} dx \cong \Delta \sum_{i=0}^{N-1} \frac{4}{1+x_i^2}$$

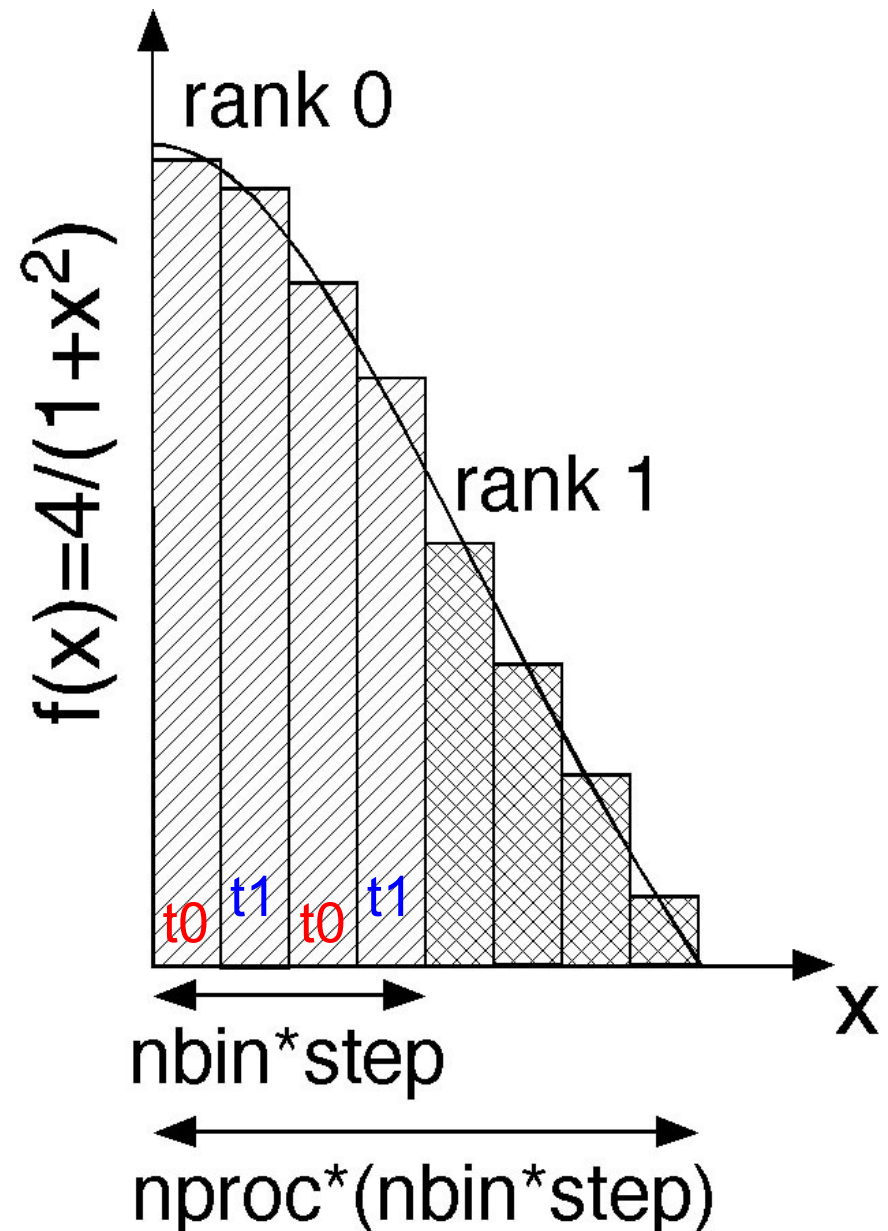

MPI+OpenMP Calculation of π : `hpi.c`

```
#include <stdio.h>
#include <mpi.h>
#include <omp.h>
#define NBIN 100000
#define MAX_THREADS 8
void main(int argc, char **argv) {
    int nbin, myid, nproc, nthreads, tid;
    double step, sum[MAX_THREADS]={0.0}, pi=0.0, pig;
    MPI_Init(&argc, &argv);
    MPI_Comm_rank(MPI_COMM_WORLD, &myid);
    MPI_Comm_size(MPI_COMM_WORLD, &nproc);
    nbin = NBIN/nproc; step = 1.0/(nbin*nproc);
    omp_set_num_threads(2);
    #pragma omp parallel private(tid)
    {
        int i;
        double x;
        nthreads = omp_get_num_threads();
        tid = omp_get_thread_num();
        for (i=nbin*myid+tid; i<nbin*(myid+1); i+=nthreads) {
            x = (i+0.5)*step; sum[tid] += 4.0/(1.0+x*x);
            printf("rank tid sum = %d %d %e\n", myid, tid, sum[tid]);
        }
        for (tid=0; tid<nthreads; tid++) pi += sum[tid]*step;
    }
    MPI_Allreduce(&pi, &pig, 1, MPI_DOUBLE, MPI_SUM, MPI_COMM_WORLD);
    if (myid==0) printf("PI = %f\n", pig);
    MPI_Finalize();
}
```

<https://aiichironakano.github.io/cs596/src/hybrid/hpi.c>

Shared variables among all threads

$NBIN \rightarrow \lfloor NBIN/nproc \rfloor \times nproc$
of bins per rank
= $\overbrace{nbin} \times nproc$

Local variables: Different values needed for different threads

Who does what!

Inter-thread reduction

Inter-rank reduction

MPI+OpenMP Example: hpi.c

- **Compilation on discovery.usc.edu**

```
mpicc -o hpi hpi.c -fopenmp
```

- **Slurm script**

```
#!/bin/bash
#SBATCH --nodes=2
#SBATCH --ntasks-per-node=1
#SBATCH --cpus-per-task=2
#SBATCH --time=00:00:59
#SBATCH --output=hpi.out
#SBATCH -A anakano_429
mpirun -n $SLURM_NNODES ./hpi
```

Socket 0

Socket 1
(exposed
8-core
micro-
processor)

Number
of nodes

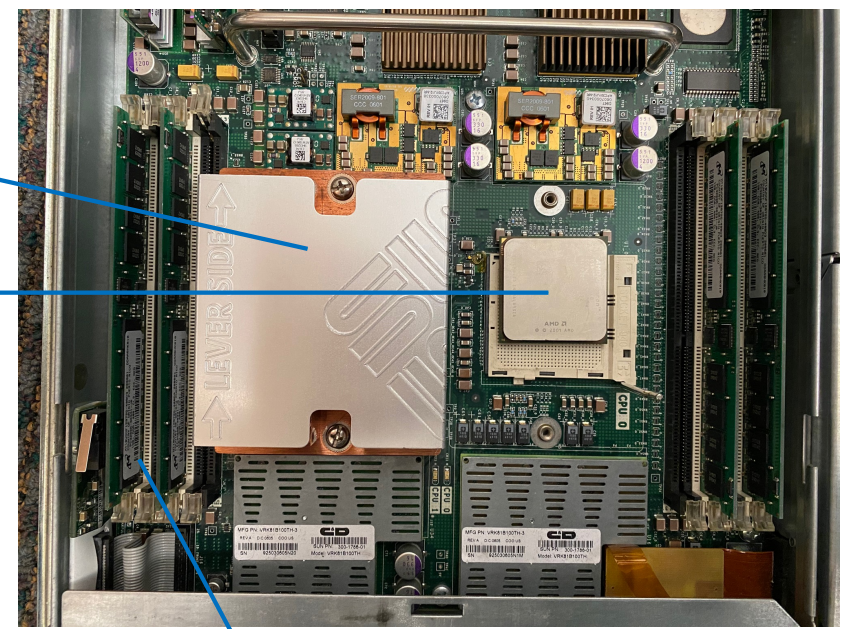

- **Output**

```
rank tid sum = 1 1 6.434981e+04
rank tid sum = 1 0 6.435041e+04
rank tid sum = 0 0 9.272972e+04
rank tid sum = 0 1 9.272932e+04
PI = 3.141593
```

- **Find information about Slurm nodes & partitions**

```
[anakano@discovery ~]$ sinfo View information
PARTITION AVAIL  TIMELIMIT  NODES  STATE NODELIST
main*      up    2-00:00:00    281   mix  d05-[08-15,26-29,31-37,39,42],...
epyc-64    up    2-00:00:00    26   alloc b22-[01-09,11-25,28-29]
...

[anakano@discovery ~]$ sinfo2 View detailed information
NODELIST PARTITION STATE   NODES  SOCKETS  CORES  MEMORY  GRES  ACTIVE_FEATURES
e13-35   main*    down*    1      2        8     63400  (null) xeon-2640v3
...
```

Hybrid MPI+OpenMP Parallel MD

- OpenMP threads handle blocks of linked-list cells in each MPI process (= spatial-decomposition subsystem)

Big picture = who does what: loop index \longrightarrow thread map

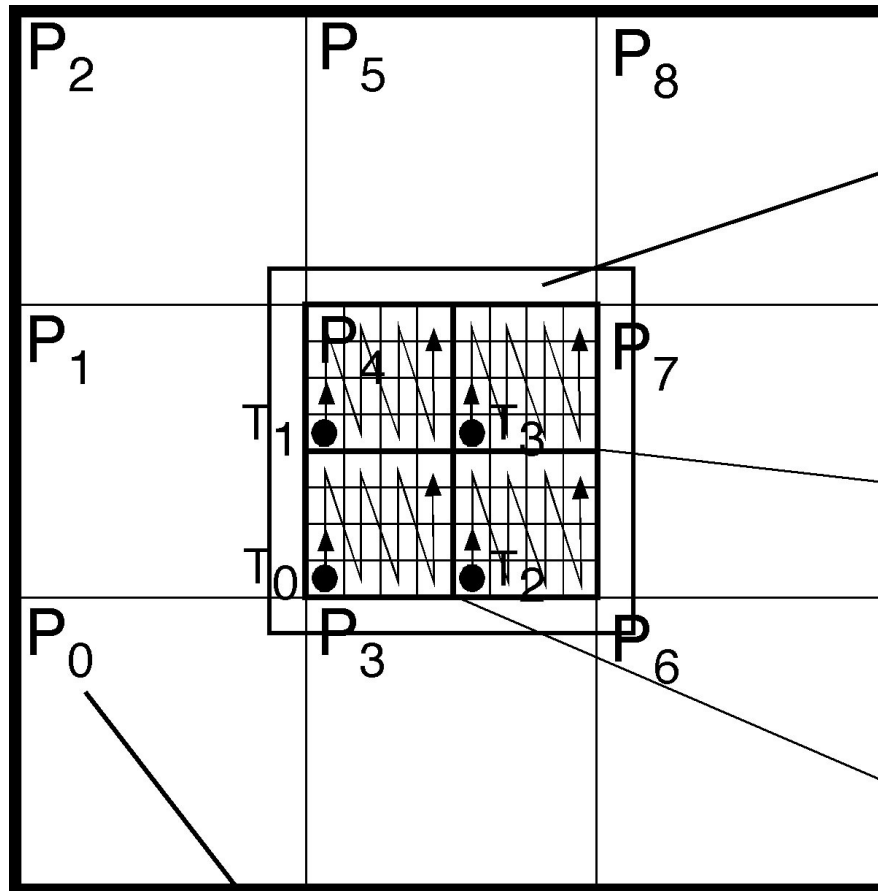

MPI process = spatial decomposition subsystem

Cached layer of linked-list cells

See the outermost loop over `mc[3]` in function `compute_accel()` in program `pmd.c`

<https://aiichironakano.github.io/cs596/src/pmd/pmd.c>

Linked-list cell

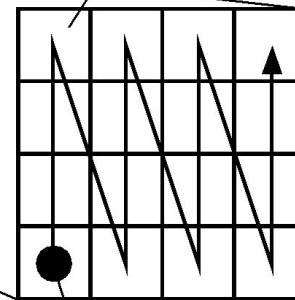

Thread processing a block of cells in a raster-scan order

Linked-List Cell Block

Variables

- **vthrd[0 | 1 | 2]** = # of OpenMP threads per MPI process in the x|y|z direction.
- **nthrd** = # of OpenMP threads = vthrd[0]×vthrd[1]×vthrd[2].
- **thbk[3]**: thbk[0 | 1 | 2] is the # of linked-list cells in the x|y|z direction that each thread is assigned.

In main():

```
omp_set_num_threads(nthrd);
```

In init_params():

```
/* Compute the # of cells for linked-list cells */  
for (a=0; a<3; a++) {  
    lc[a] = al[a]/RCUT; // Cell size ≥ potential cutoff  
    /* Size of cell block that each thread is assigned */  
    thbk[a] = lc[a]/vthrd[a];  
    /* # of cells = integer multiple of the # of threads */  
    lc[a] = thbk[a]*vthrd[a]; // Adjust # of cells/MPI process  
    rc[a] = al[a]/lc[a]; // Linked-list cell length  
}
```

In hmd.h:

```
int vthrd[3]={2,2,1},nthrd=4;  
int thbk[3];
```

OpenMP Threads for Cell Blocks

Variables

- **std** = scalar thread index.
- **vtd[3]: vtd[0 | 1 | 2]** is the x|y|z element of vector thread index.
- **mofst[3]: mofst[0 | 1 | 2]** is the x|y|z offset cell index of cell-block.

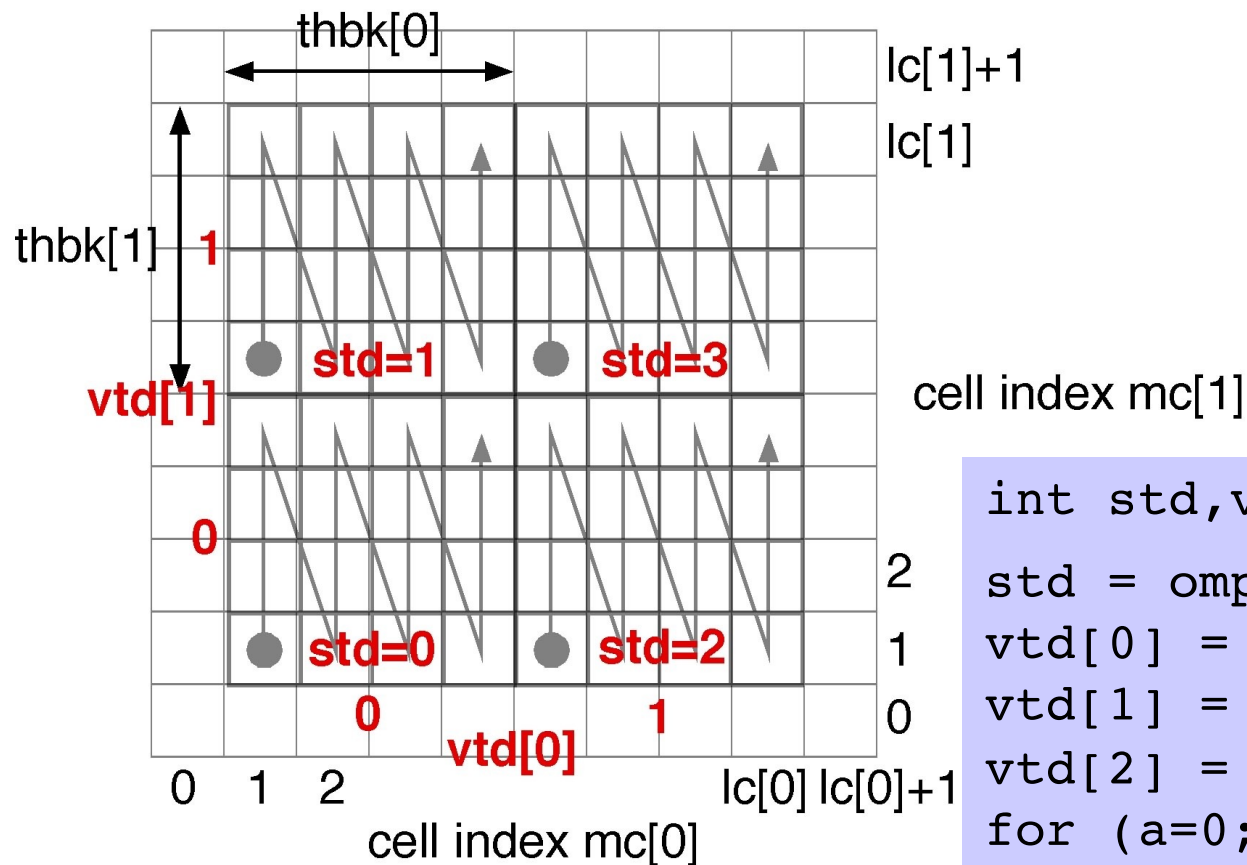

```
int std, vtd[3], mofst[3];
std = omp_get_thread_num();
vtd[0] = std / (vthrd[1] * vthrd[2]);
vtd[1] = (std / vthrd[2]) % vthrd[1];
vtd[2] = std % vthrd[2];
for (a=0; a<3; a++)
    mofst[a] = vtd[a] * thbk[a];
```

Call **omp_get_thread_num()** within an OpenMP parallel block.

Threads Processing of Cell Blocks

Start from your `pmd_irecv.c` instead

- Start with the MPI parallel MD program, `pmd.c`
- Within each MPI process, parallelize the outer loops over central linked-list cells, `mc[]`, in the force computation function, `compute_accel()`, using OpenMP threads
- If each thread needs separate copy of a variable (*e.g.*, loop index `mc[]`), declare it as `private` in the OpenMP parallel block

```
#pragma omp parallel private(mc,...)
{
    ...
    for (mc[0]=mofst[0]+1; mc[0]<=mofst[0]+thbk[0]; (mc[0])++)
    for (mc[1]=mofst[1]+1; mc[1]<=mofst[1]+thbk[1]; (mc[1])++)
    for (mc[2]=mofst[2]+1; mc[2]<=mofst[2]+thbk[2]; (mc[2])++) {
        Each thread handles thbk[0]×thbk[1]×thbk[2] cells independently
    }
    ...
} // End omp parallel
```

Avoiding Critical Sections (1)

- Remove the critical section

```
if (bintra) lpe += vVal; else lpe += 0.5*vVal;
```

by defining an array, `lpe_td[nthrd]`, where each array element stores the partial sum of the potential energy by a thread

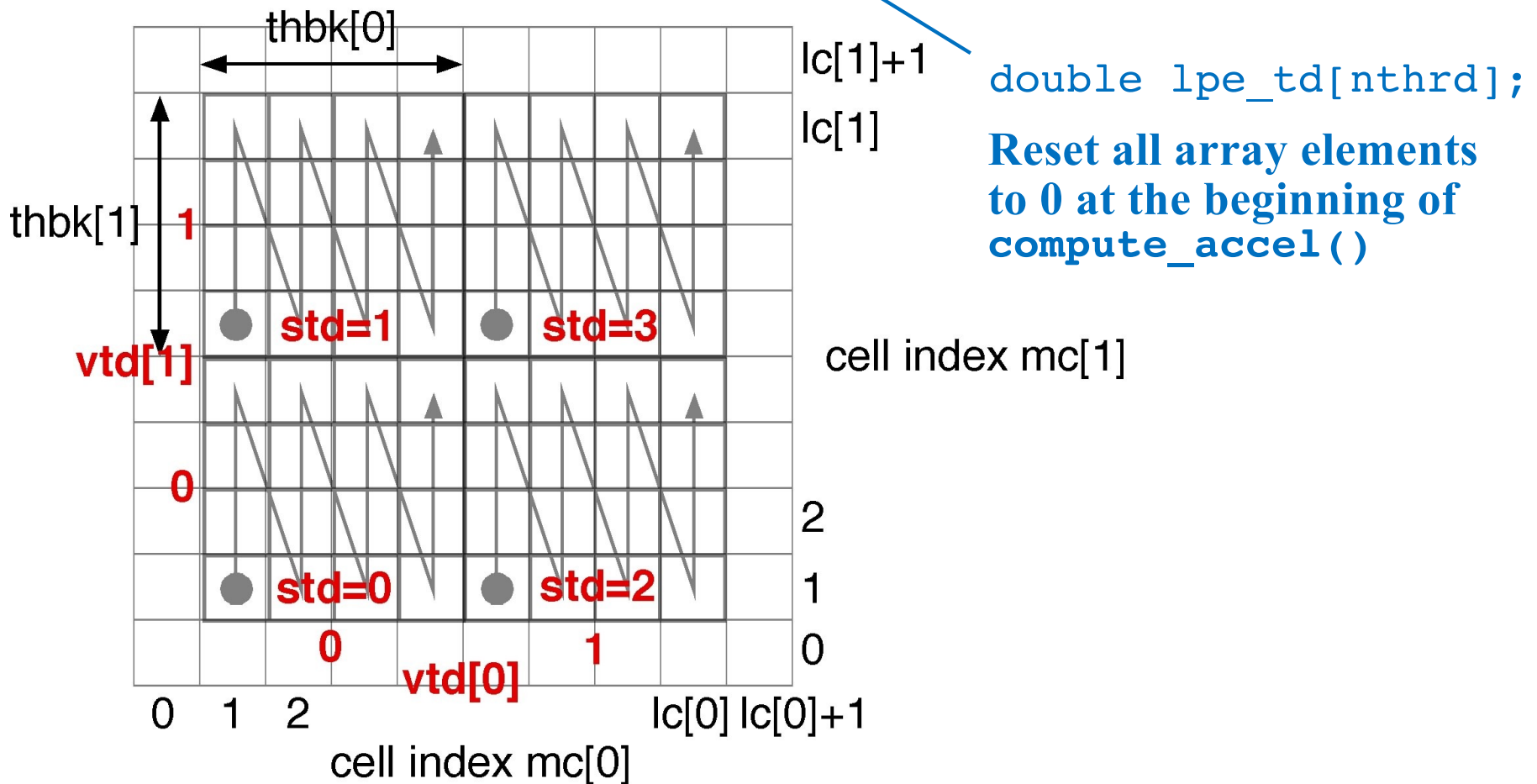

Data privatization: *cf. omp_pi.c & hpi.c*

Avoiding Critical Sections (2)

- To avoid multiple threads to access an identical force array element, stop using the Newton's third law:

```

int bintra;
...
bintra = (j < n);
...
if (i < j && rr < rrCut) {
    ...
    if (bintra) lpe += vVal; else lpe_td[std] += 0.5*vVal;
    for (a=0; a<3; a++) {
        f = fcVal*dr[a];
        ra[i][a] += f;
        if (bintra) ra[j][a] -= f;
    }
}

```

Note the data privatization

Mutually exclusive access to ra[][] for preventing race conditions

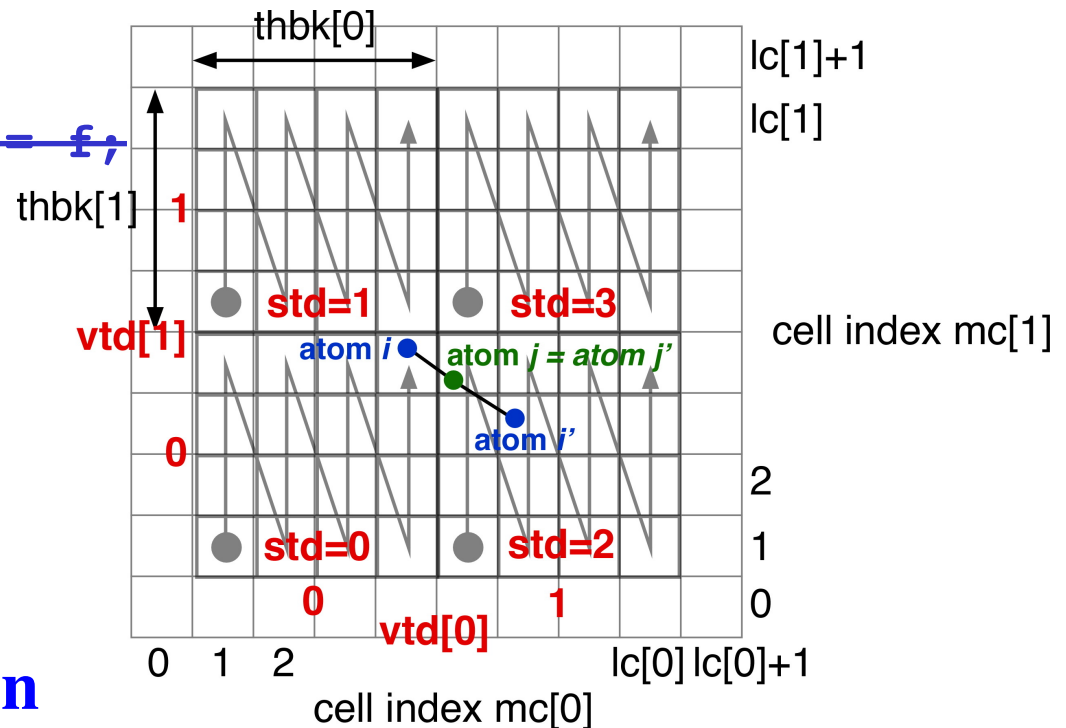

- Interthread reduction after join

```
for (i=0; i<nthrd; i++) lpe += lpe_td[i];
```

OpenMP Essential

define shared;

... if used here

```
#pragma omp parallel private(if used in both)  
{  
  define private;  
  ... if only used (in left-hand side) here  
}
```

... or here

Running HMD at CARC

- **Submit a batch job using the following Slurm script.**

```
#!/bin/bash
#SBATCH --nodes=2
#SBATCH --ntasks-per-node=1
#SBATCH --cpus-per-task=4
#SBATCH --time=00:01:59
#SBATCH --output=hmd.out
#SBATCH -A anakano_429

mpirun -bind-to none -n 2 ./hmd
```

 **To be explained later**

- **Note that hmd.c must have been compiled in the same directory as you submit this Slurm script:**

```
mpicc -O -o hmd hmd.c -lm -fopenmp
```

Interactively Running HMD at CARC (1)

1. Interactively submit a Slurm job & wait until you are allocated nodes.
(Note that you will be automatically logged in to one of the allocated nodes.)

```
$ salloc --nodes=2 --ntasks-per-node=1 --cpus-per-task=4 -t 29
salloc: Pending job allocation 6064886
salloc: job 6064886 queued and waiting for resources
salloc: job 6064886 has been allocated resources
salloc: Granted job allocation 6064886
[anakano@d05-35 ~]$
```

 You are logged in to one of the allocated nodes

For CPU information, type `more /proc/cpuinfo`

Interactively Running HMD at CARC (2)

- Submit a two-process MPI program (named hmd); each of the MPI process will spawn 4 OpenMP threads.

```
[anakano@d05-35 cs596]$ mpirun -bind-to none -n 2 ./hmd
```

- While the job is running, you can **open another window & log in to the node (or the other allocated node) to check that all processors are busy using top command. Type 'H' to show individual threads (type 'q' to stop).**

```
[anakano@discovery ~]$ ssh d05-35  
[anakano@d05-35 ~]$ top (then type H)
```

```
...  
PID USER      PR  NI    VIRT    RES    SHR S  %CPU  %MEM    TIME+  COMMAND  
29861 anakano   20   0  443776  102836  7976 R  99.9   0.1   0:09.12 hmd  
29871 anakano   20   0  443776  102836  7976 R  99.9   0.1   0:09.06 hmd  
29869 anakano   20   0  443776  102836  7976 R  99.7   0.1   0:09.02 hmd  
29870 anakano   20   0  443776  102836  7976 R  99.7   0.1   0:09.04 hmd  
29661 anakano   20   0  164504    2624   1628 R   0.3   0.0   0:02.34 top  
1 root      20   0   43572    3944   2528 S   0.0   0.0   2:06.33 systemd  
...
```

Interactively Running HMD at CARC (3)

4. Type '1' to show core-usage summary.

```
top - 12:36:48 up 48 days, 23:35, 1 user, load average: 3.62, 3.75, 2.86
Threads: 378 total, 5 running, 373 sleeping, 0 stopped, 0 zombie
%Cpu0  :  0.3 us,  0.0 sy,  0.0 ni, 99.7 id,  0.0 wa,  0.0 hi,  0.0 si,  0.0 st
%Cpu1  :100.0 us,  0.0 sy,  0.0 ni,  0.0 id,  0.0 wa,  0.0 hi,  0.0 si,  0.0 st
%Cpu2  : 99.7 us,  0.3 sy,  0.0 ni,  0.0 id,  0.0 wa,  0.0 hi,  0.0 si,  0.0 st
%Cpu3  :100.0 us,  0.0 sy,  0.0 ni,  0.0 id,  0.0 wa,  0.0 hi,  0.0 si,  0.0 st
%Cpu4  :100.0 us,  0.0 sy,  0.0 ni,  0.0 id,  0.0 wa,  0.0 hi,  0.0 si,  0.0 st
%Cpu5  :  0.0 us,  0.0 sy,  0.0 ni,100.0 id,  0.0 wa,  0.0 hi,  0.0 si,  0.0 st
%Cpu6  :  0.0 us,  0.3 sy,  0.0 ni, 99.7 id,  0.0 wa,  0.0 hi,  0.0 si,  0.0 st
%Cpu7  :  0.0 us,  0.0 sy,  0.0 ni,100.0 id,  0.0 wa,  0.0 hi,  0.0 si,  0.0 st
...
%Cpu19 :  0.0 us,  0.0 sy,  0.0 ni,100.0 id,  0.0 wa,  0.0 hi,  0.0 si,  0.0 st
```

Interactively Running HMD at CARC (4)

5. Without `-bind-to none` option, hmd process (and all spawned threads by it) is bound to one core.

```
[anakano@d05-35 cs596]$ mpirun -n 2 ./hmd
```

```
[anakano@d05-36 ~]$ top
```

...

PID	USER	PR	NI	VIRT	RES	SHR	S	%CPU	%MEM	TIME+	COMMAND
29363	anakano	20	0	443556	108340	7580	R	27.9	0.1	0:18.43	hmd
29373	anakano	20	0	443556	108340	7580	S	24.3	0.1	0:15.96	hmd
29371	anakano	20	0	443556	108340	7580	S	23.9	0.1	0:16.06	hmd
29372	anakano	20	0	443556	108340	7580	S	23.9	0.1	0:15.96	hmd
29341	anakano	20	0	164504	2476	1608	R	0.7	0.0	0:00.37	top
1	root	20	0	43572	3944	2528	S	0.0	0.0	2:06.30	systemd

...

How Hybrid MPI+OpenMP MD Runs

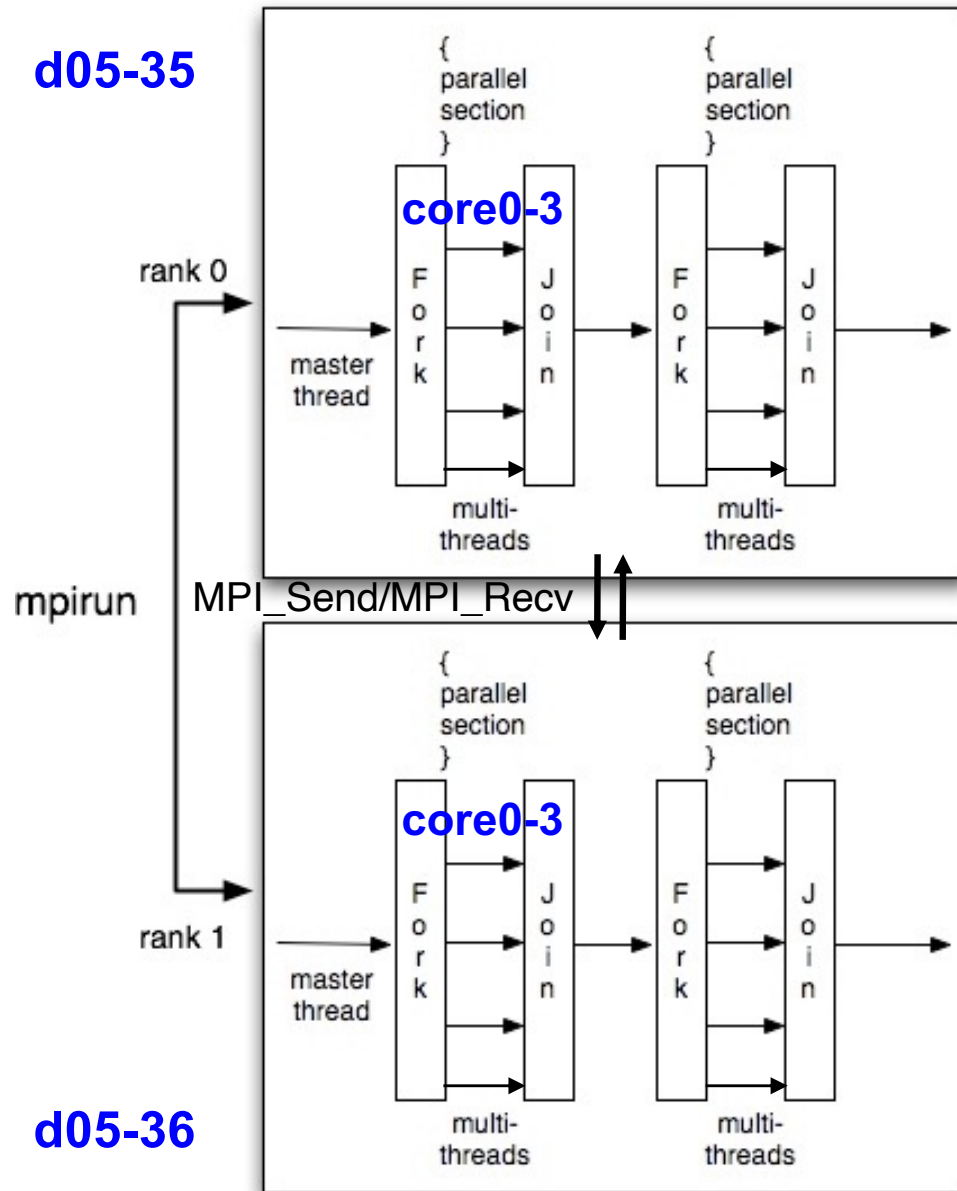

In hmd.h:

```
int vproc[3] = {1,1,2}, nproc = 2;  
int vthrd[3] = {2,2,1}, nthrd = 4;
```

In hmd.c:

```
omp_set_num_threads(nthrd);
```

On discovery:

```
salloc --nodes=2 --ntasks-per-node=1  
--cpus-per-task=4 -t 30
```

On d05-35:

```
mpirun -bind-to none -n 2 ./hmd
```

On d05-35 & d05-36:

```
top (then type H and 1)
```

Try it yourself!

Validation of Hybrid MD

2 MPI process; 4 threads

In `hmd.h`:

```
vproc = {1,1,2}, nproc = 2;  
vthrd = {2,2,1}, nthrd = 4;
```

Make sure that the total energy is the same as that calculated by `pmd.c` using the same input parameters, at least for ~5-6 digits

`pmd.in`

```
24 24 12 InitUcell[3]  
0.8      Density  
1.0     InitTemp  
0.005   DeltaT  
100     StepLimit  
10      StepAvg
```

0.050000	0.877345	-5.137153	-3.821136
0.100000	0.462056	-4.513097	-3.820013
0.150000	0.510836	-4.587287	-3.821033
0.200000	0.527457	-4.611958	-3.820772
0.250000	0.518668	-4.598798	-3.820796
0.300000	0.529023	-4.614343	-3.820808
0.350000	0.532890	-4.620133	-3.820798
0.400000	0.536070	-4.624899	-3.820794
0.450000	0.539725	-4.630387	-3.820799
0.500000	0.538481	-4.628514	-3.820792

Time

Temperature Potential energy

Total energy

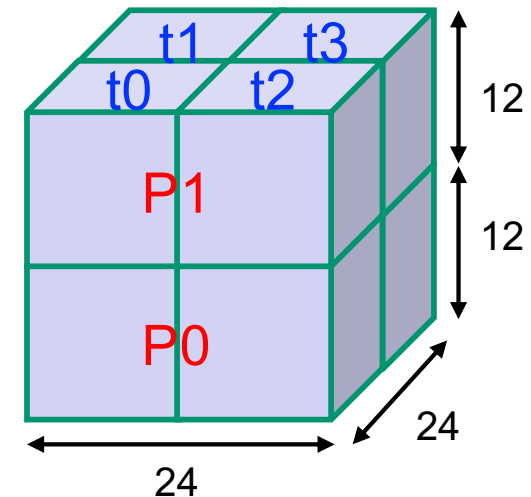

See the lecture on order-invariant real-number summation

Strong Scalability of Hybrid MD

1 MPI process; 1-8 threads

In `hmd.h`:

```
vproc = {1,1,1}, nproc = 1;
vthrd = {1,1,1}, nthrd = 1;
        2 1 1           2
        2 2 1           4
        2 2 2           8
```

`pmd.in`

```
24 24 24 InitUcell[3]
0.8      Density
1.0      InitTemp
0.005    DeltaT
100      StepLimit
101      StepAvg
```

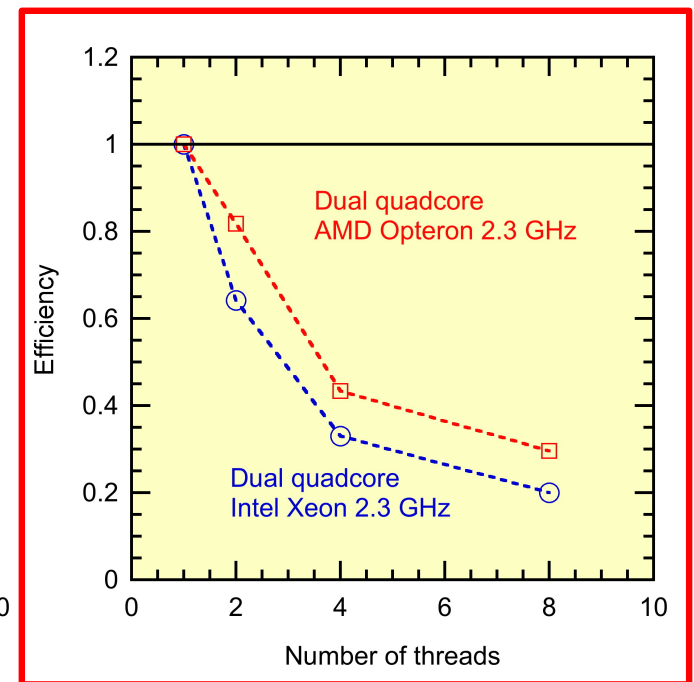
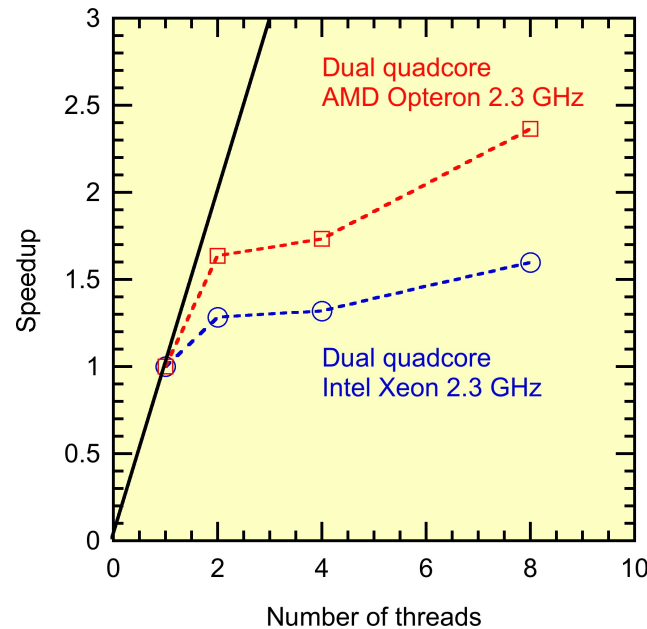
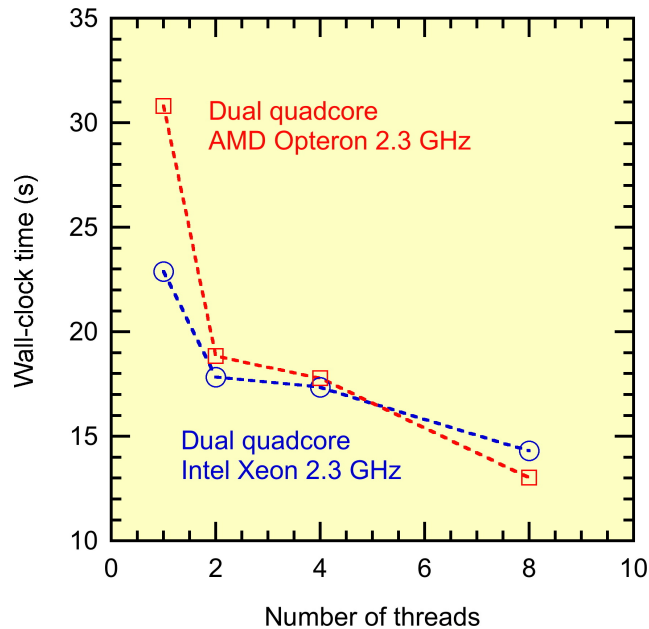

`InitUcell[] = {24,24,24}`

$N = 4 \times 24^3$
= 55296 atoms

$$S_P = \frac{T(N,1)}{T(N,P)}$$

P : Number of cores

$$E_P = \frac{S_P}{P}$$

Improved Strong Scalability of Hybrid MD

1 MPI process; 1-8 threads

In hmd.h:

```
vproc = {1,1,1}, nproc = 1;
vthrd = {1,1,1}, nthrd = 1;
          2 1 1           2
          2 2 1           4
          2 2 2           8
```

```
#SBATCH --nodes=1
#SBATCH --ntasks-per-node=1
#SBATCH --cpus-per-task=8

mpirun ... -n 1 ... ./hmd1
                                     2
                                     4
                                     8
```

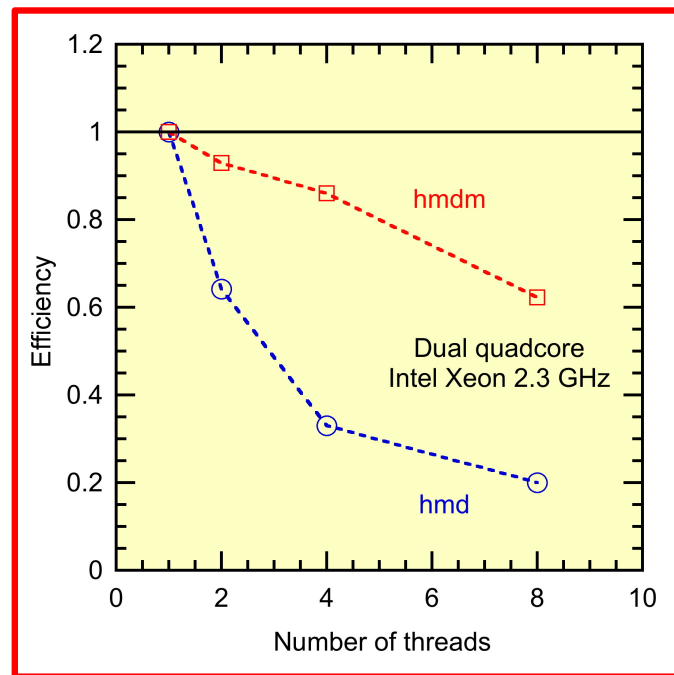
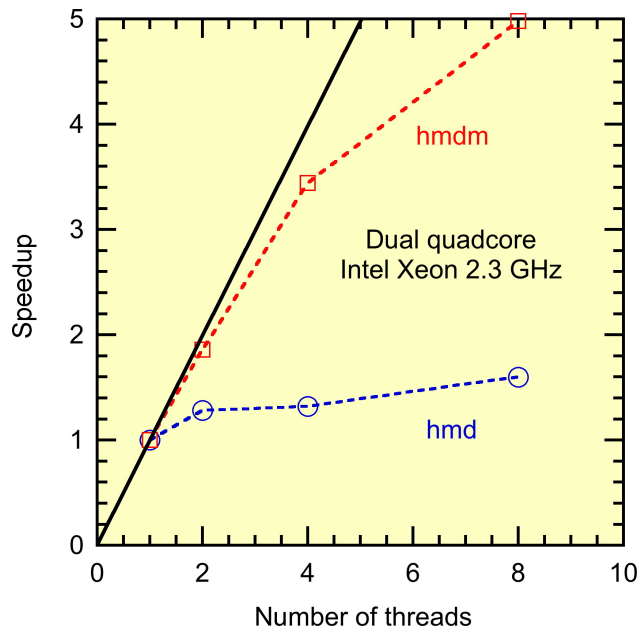
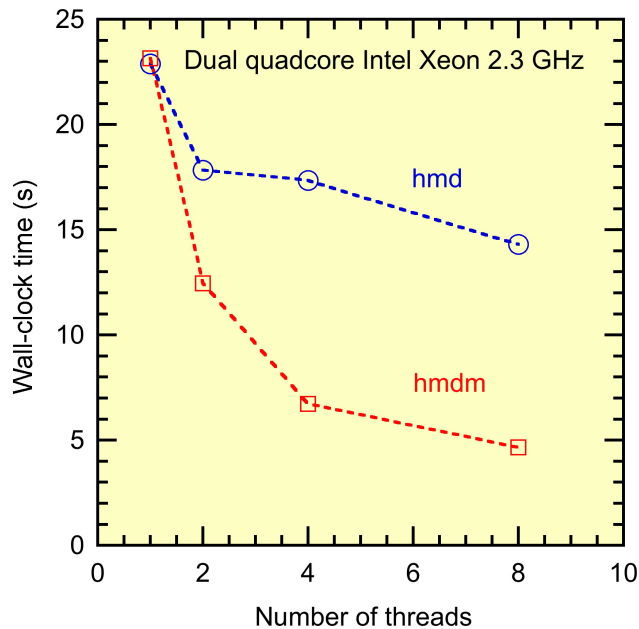

InitUcell[] = {24,24,24}

$N = 4 \times 24^3$
= 55296 atoms

$$S_P = \frac{T(N,1)}{T(N,P)}$$

P : Number of cores

$$E_P = \frac{S_P}{P}$$

More on Multithreading MD

- Large overhead is involved in opening an OpenMP parallel section
→ Open it only once in the main function

In hmdm.c:

```
int main() {  
    ...  
    omp_set_num_threads(nthrd);  
    #pragma omp parallel  
    {  
        #pragma omp master  
        { // Do serial computations here}  
        ...  
        #pragma omp barrier // When threads need be synchronized  
        ...  
    }  
    ...  
}
```

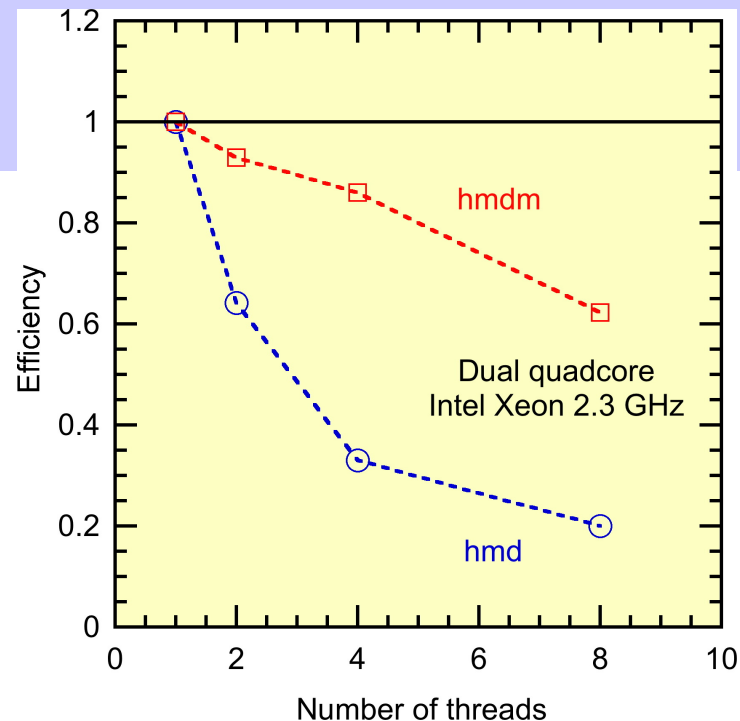

More on Avoiding Race Conditions

- Program `hmd.c`: (1) used data privatization; (2) disabled the use of Newton's third law → this doubled computation
- **Cell-coloring**
 - > Race condition-free multithreading without duplicating pair computations
 - > Color cells such that no cells of the same color are adjacent to each other
 - > Threads process cells of the same color at a time in a color loop

1	3	1	3	1	3
0	2	0	2	0	2
1	3	1	3	1	3
0	2	0	2	0	2
1	3	1	3	1	3
0	2	0	2	0	2

Four-color (eight colors in 3D) solution
requires the cell size to be twice the
cutoff radius r_c

H. S. Byun *et al.*,
Comput. Phys. Commun.
219, 246 ('17)

- Use graph coloring in more general computations

False Sharing

- While eliminating race conditions by data privatization, the use of consecutive per-thread accumulators, `lpe_td[nthrd]`, degrades performance by causing excessive cache misses

See [false sharing](#) Wiki page

- **Solution 1: Padding**

```
struct lpe_t {
    double lpe;
    double pads[7]; // assume intel CPU with 64 byte cache line
};
struct lpe_t lpe_td[nthrd];
```

- **Solution 2: System-supported data privatization**

```
#pragma omp parallel private (...) reduction(+:lpe)
{
    ...
    lpe += 0.5*vVal;
    ...
}
// No reduction over the threads is required here
```

1. Create private copies of the variable (`lpe`) in the reduction clause for all the threads
2. Perform the specified reduction operation (+) on the variable at the end of the parallel section

Scalability Test: False Sharing Matters

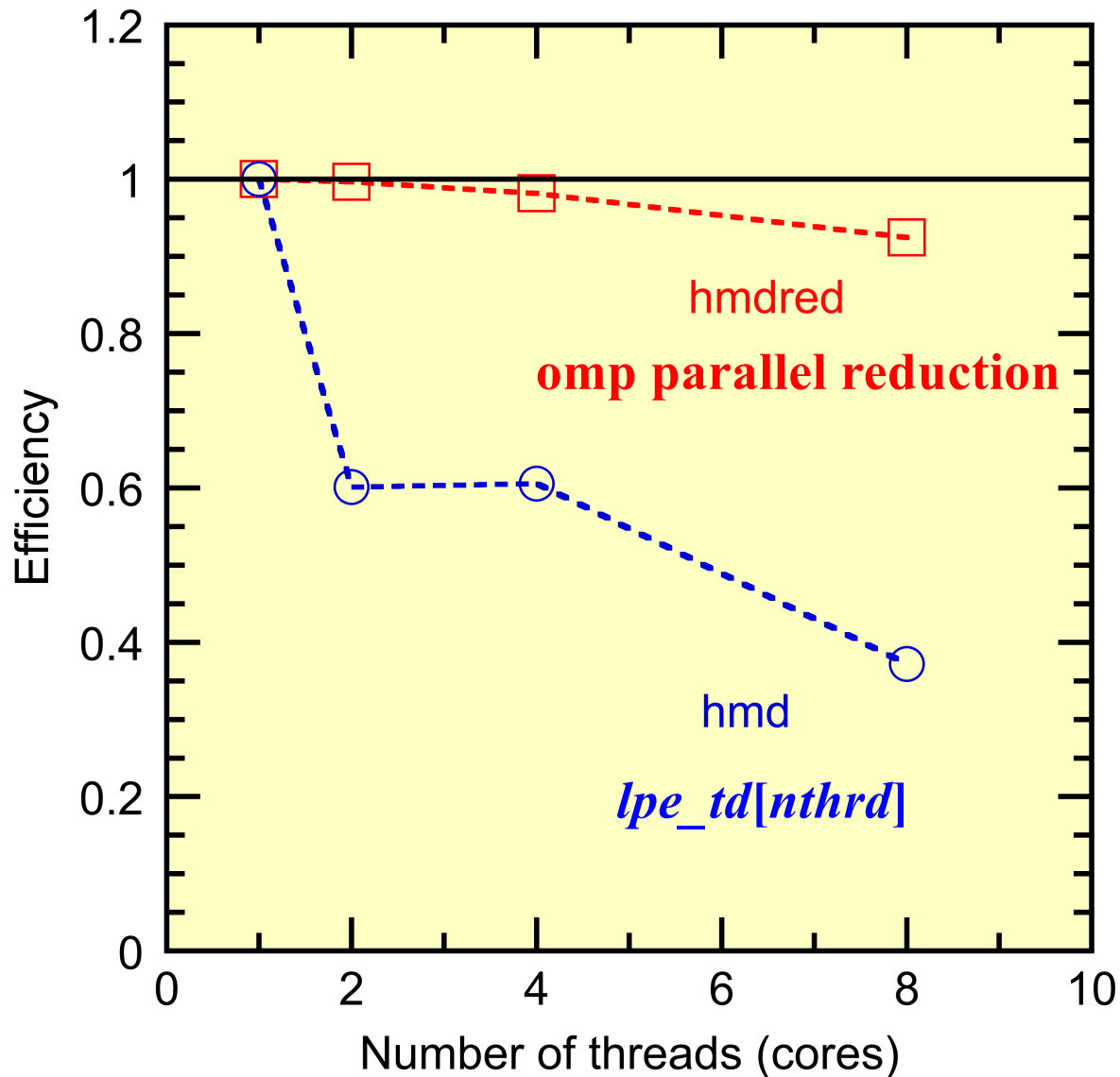

- **Having now understood how multithreading works, start using reduction clause in real-life code development**

Some Like It as Arguments

- Use command line arguments for scaling tests without re-compiling multiple times
- `hmd.c` → `hmdarg.c` by adding the following lines in `main()`

```
int main(int argc, char **argv) {  
    ...  
    vthrd[0] = atoi(argv[1]);  
    vthrd[1] = atoi(argv[2]);  
    vthrd[2] = atoi(argv[3]);  
    nthrd = vthrd[0]*vthrd[1]*vthrd[2];  
    printf("Number of threads = %d\n", nthrd);  
    ...  
}
```

string-to-integer conversion

command-line argument

- **Compiling**

```
mpicc -o hmdarg hmdarg.c -fopenmp -lm
```

Strong-Scaling Test with hmdarg.c

```
[anakano@discovery cs596]$ salloc --nodes=1 --ntasks-per-node=1 --cpus-per-  
task=8 -t 59  
...  
[anakano@d05-29 cs596]$ mpirun -bind-to none -n 1 ./hmdarg 1 1 1  
Number of threads = 1  
al = 4.103942e+01 4.103942e+01 4.103942e+01  
lc = 16 16 16  
rc = 2.564964e+00 2.564964e+00 2.564964e+00  
thbk = 16 16 16  
nglob = 55296  
CPU & COMT = 1.073547e+01 2.005649e-02  
[anakano@d05-29 cs596]$ mpirun -bind-to none -n 1 ./hmdarg 2 1 1  
Number of threads = 2  
...  
thbk = 8 16 16  
nglob = 55296  
CPU & COMT = 6.804797e+00 1.980424e-02  
[anakano@d05-29 cs596]$ mpirun -bind-to none -n 1 ./hmdarg 2 2 1  
Number of threads = 4  
...  
thbk = 8 8 16  
nglob = 55296  
CPU & COMT = 4.956142e+00 1.981378e-02  
[anakano@d05-29 cs596]$ mpirun -bind-to none -n 1 ./hmdarg 2 2 2  
Number of threads = 8  
...  
thbk = 8 8 8  
nglob = 55296  
CPU & COMT = 4.078273e+00 2.253795e-02
```

Atomic Operation

- Restore Newton's third law & handle race conditions with the `omp atomic` directive

```
int bintra;
...
if (i<j && rr<rrCut) {
    ...
    if (bintra)
        lpe_td[std] += vVal;
    else
        lpe_td[std] += 0.5*vVal;
    for (a=0; a<3; a++) {
        f = fcVal*dr[a];
        ra[i][a] += f;
        if (bintra) {
            #pragma omp atomic
            ra[j][a] -= f; // Different threads can access the same atom
        }
    }
}
```

Atomic Operation Is Expensive

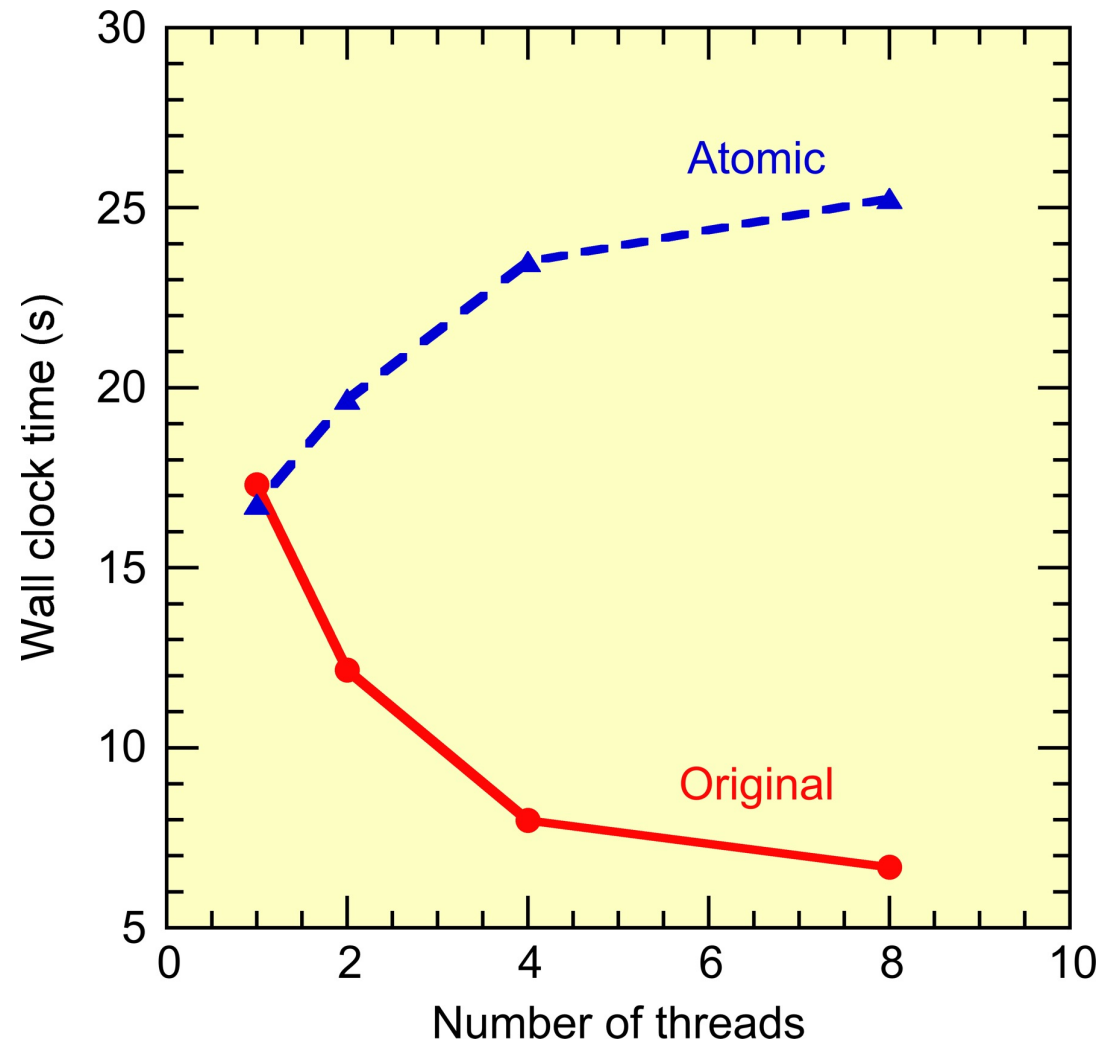

Spatially Compact Thread Scheduling

**Concurrency-control mechanism:
Data privatization (duplicate the force array)**

- **Reduced memory:** # of atoms
 $\Theta(nq) \rightarrow \Theta(n+n^{2/3}q^{1/3})$
- **Strong scaling parallel efficiency 0.9 on quad quad-core AMD Opteron**
- **2.6× speedup over MPI by hybrid MPI+OpenMP on 32,768 IBM Blue Gene/P cores**

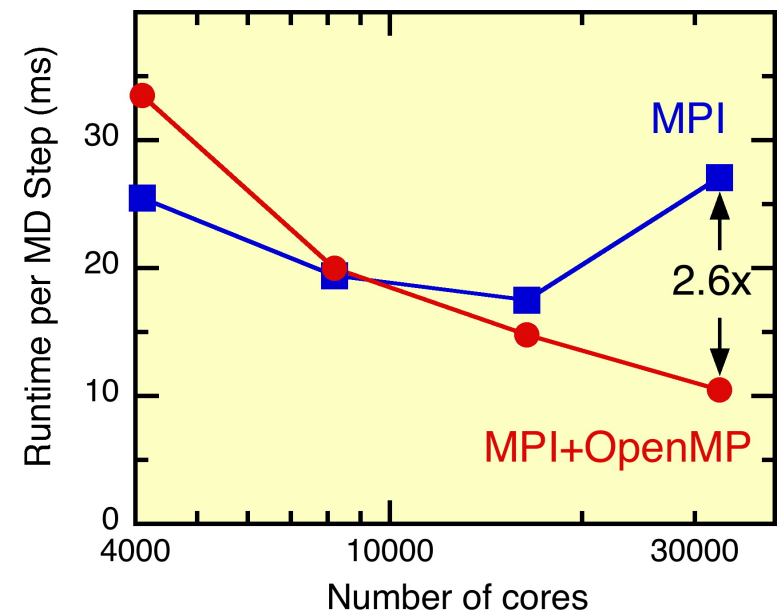
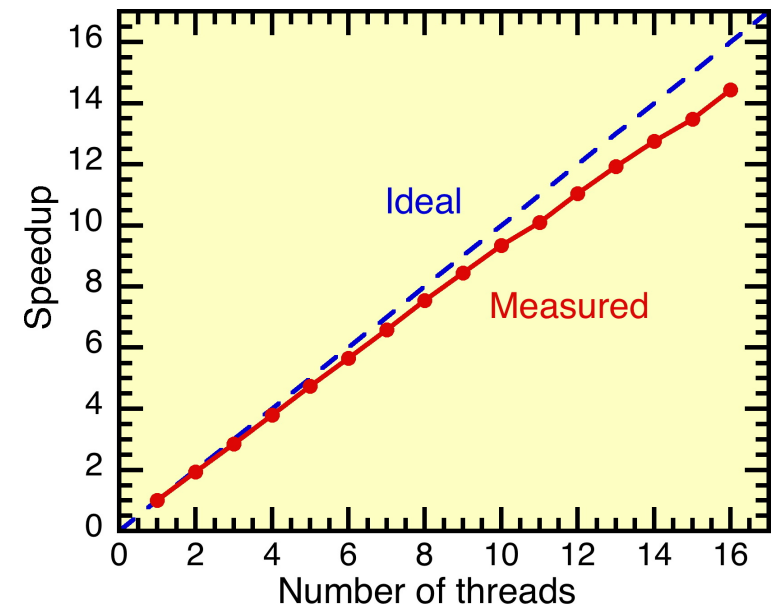
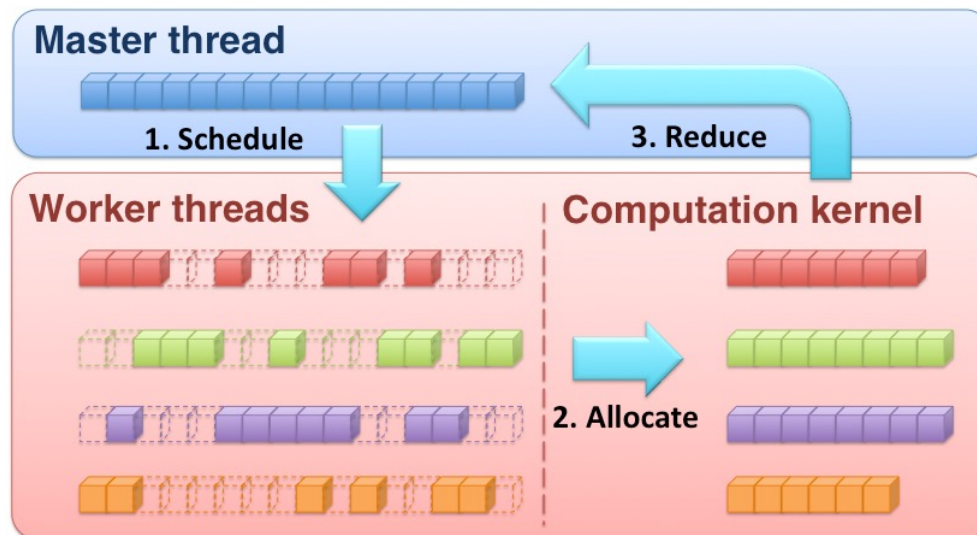

Concurrency-Control Mechanisms

A number of concurrency-control mechanisms (CCMs) are provided by OpenMP to coordinate multiple threads:

- **Critical section: Serialization**
- **Atomic update: Expensive hardware instruction**
- **Data privatization: Requires large memory $\Theta(nq)$**
- **Hardware transactional memory: Rollbacks (on IBM Blue Gene/Q)**

of atoms per node

of threads

CCM performance varies:

- Depending on computational characteristics of each program
- In many cases, CCM degrades performance significantly

HTM/critical section

```
#pragma omp <critical|tm_atomic>
{
ra[i][0] += fa*dr[0];
ra[i][1] += fa*dr[1];
ra[i][2] += fa*dr[2];
}
```

Atomic update

```
#pragma omp atomic
ra[i][0] += fa*dr[0];
#pragma omp atomic
ra[i][1] += fa*dr[1];
#pragma omp atomic
ra[i][2] += fa*dr[2];
```

Data privatization

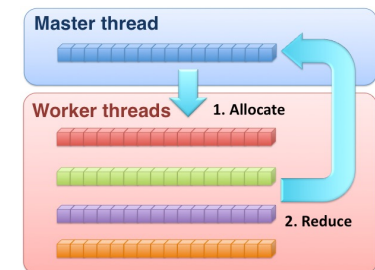

Goal: Provide a guideline to choose the “right” CCM

Hardware Transactional Memory

Transactional memory (TM): An opportunistic CCM

- Avoids memory conflicts by monitoring a set of **speculative** operations (*i.e.* **transaction**)
- If two or more transactions write to the same memory address, transaction(s) will be restarted—a process called **rollback**
- If no conflict detected in the end of a transaction, operations within the transaction becomes permanent (*i.e.* **committed**)
- Software TM usually suffers from large overhead

Hardware TM on IBM Blue Gene/Q:

- The first commercial platform implementing TM support at hardware level *via* multiversioned L2-cache
- Hardware support is expected to reduce TM overhead
- Performance of HTM on molecular dynamics has not been quantified

Strong-Scaling Benchmark for MD

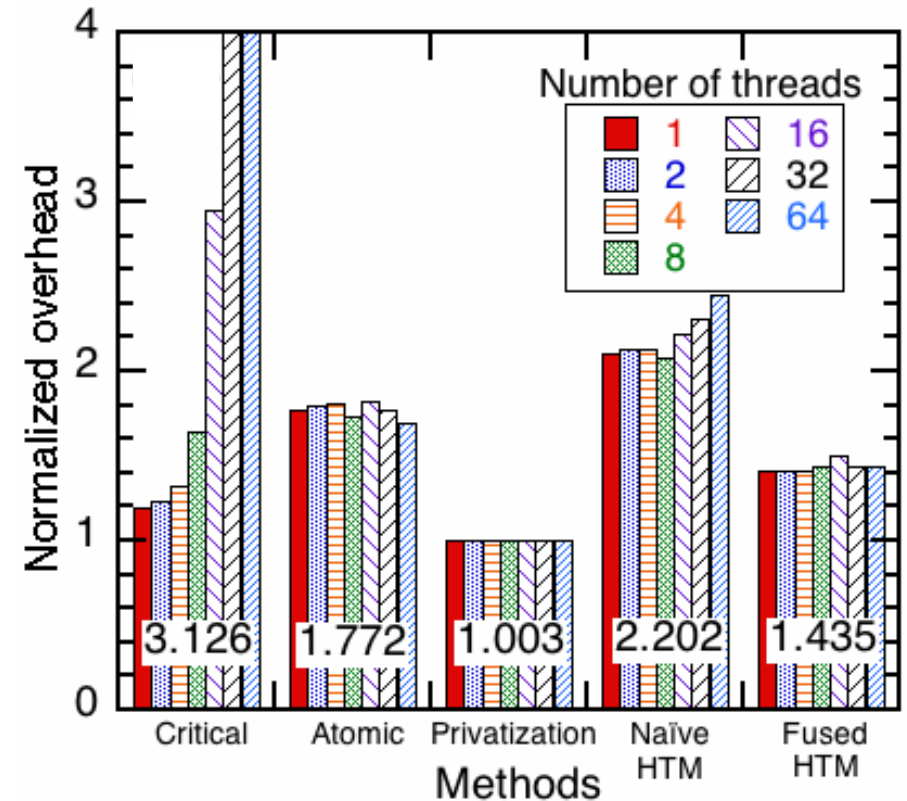
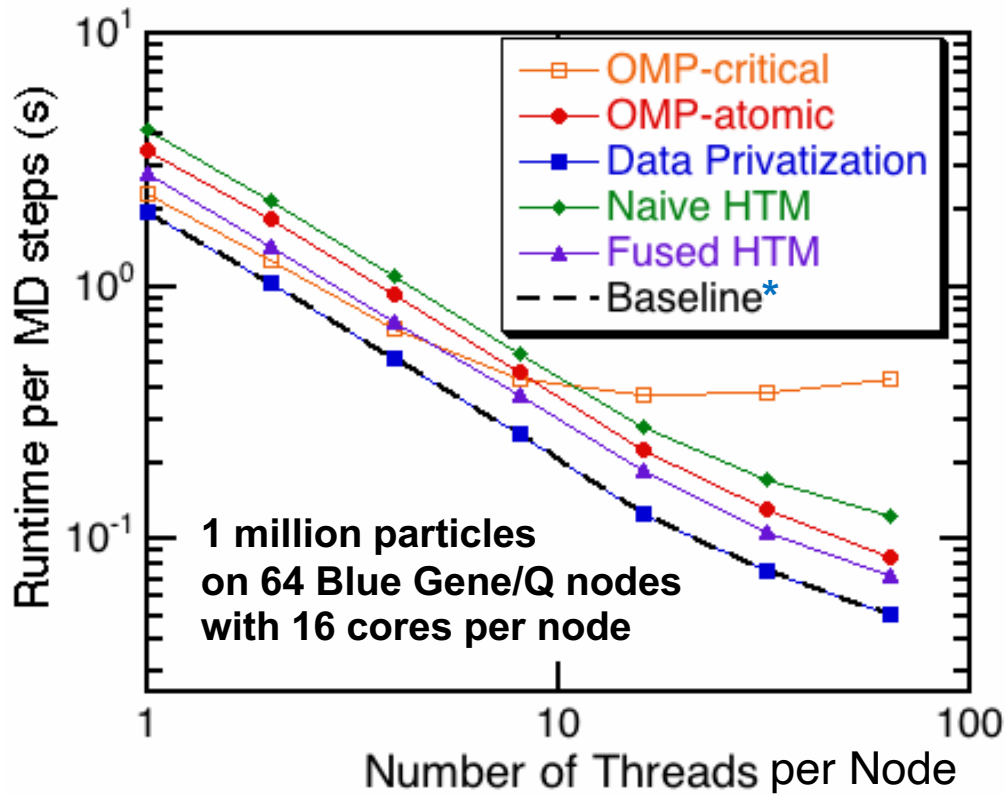

*Baseline: No CCM; the result is wrong

Developed a fundamental understanding of CCMs:

- OMP-critical has limited scalability on larger number of threads ($q > 8$)
- Data privatization is the fastest, but it requires $\Theta(nq)$ memory
- Fused HTM performs the best among constant-memory CCMs

Threading Guideline for Scientific Programs

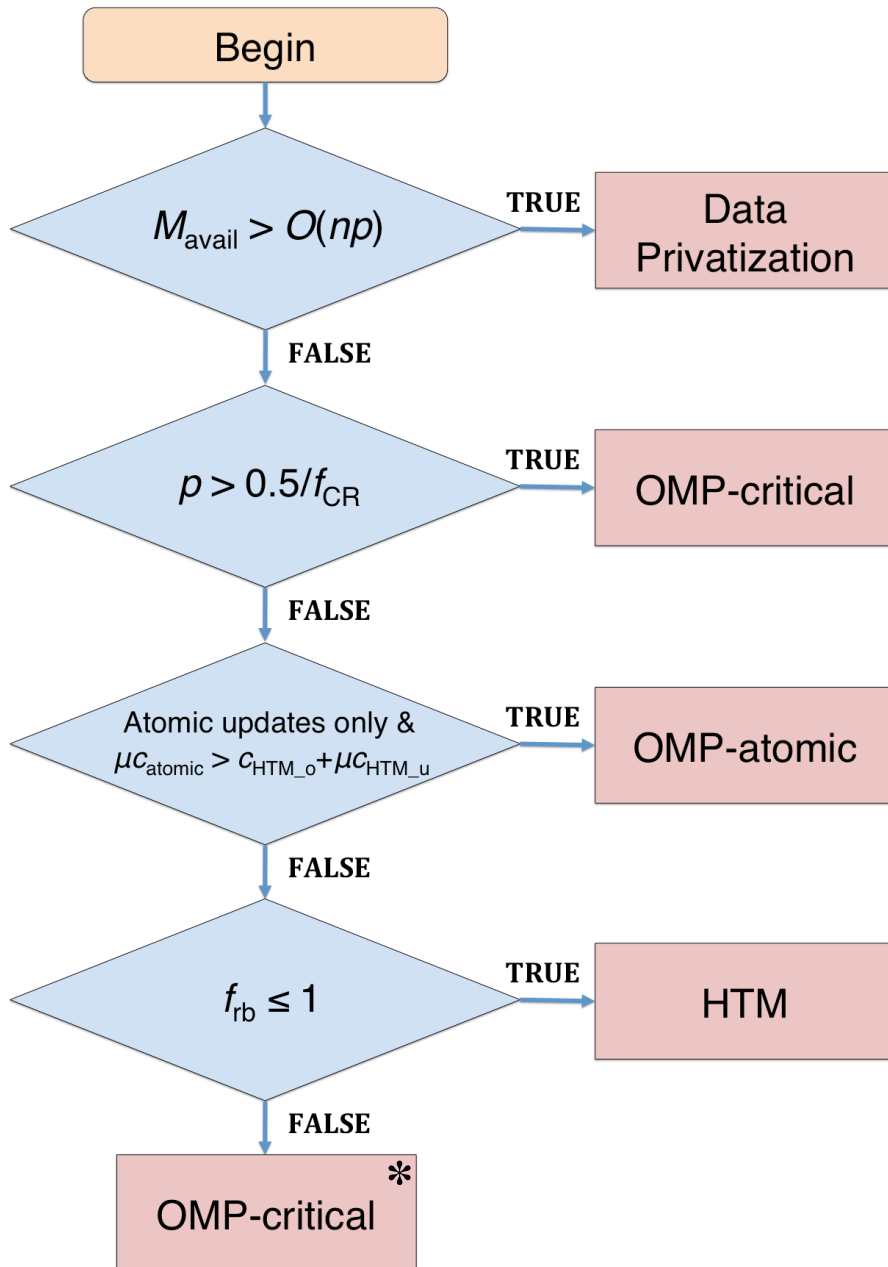

Focus on minimizing runtime (best performance):

- **Have enough memory → data privatization**
- **Conflict region is small → OMP-critical**
- **Small amount of updates → OMP-atomic**
- **Conflict rate is low → HTM**
- **Other → OMP-critical* (poor performance)**

Concurrency control mechanism	Parallel efficiency
OMP-critical	$e = \min\left(\frac{1}{pf_{CR}}, 1\right)$
OMP-atomic	$e = \frac{t_{total}}{t_{total} + m\mu c_{atomic}}$
Data privatization	$e = \frac{t_{total}}{t_{total} + c_{reduction} n \log p}$
HTM	$e = \frac{t_{total}}{t_{total} + m(c_{HTM_overhead} + \mu c_{HTM_update})}$

IEEE PDSEC Best Paper & Beyond

**IEEE PDSEC
Best Paper Award**

*Performance Characteristics of Hardware Transactional Memory for
Molecular Dynamics Application on BlueGene/Q*

*Manaschai Kunaseth, Rajiv Kalia, Aiichiro Nakano,
Priya Vashishta, David Richards, James Glosli*

The 14th IEEE International Workshop on Parallel and Distributed Scientific
and Engineering Computing (PDSEC-13), held in Boston, Massachusetts,
USA, May 24, 2013.



It All Started as a CSCI596 Final Project

