

# CSCI653: High Performance Computing & Simulations

---

**Aiichiro Nakano**

*Collaboratory for Advanced Computing & Simulations  
Department of Computer Science  
Department of Physics & Astronomy  
Department of Quantitative & Computational Biology  
University of Southern California*

**Email: [anakano@usc.edu](mailto:anakano@usc.edu)**

**Do “Your” Science Using High Performance Computing**

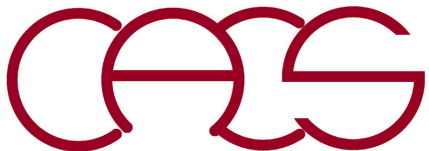

# CSCI653 at a Glance: Applications

- High performance computing (HPC) with archetypal real-world applications
  - > **Molecular dynamics (MD): interaction**  
Multiple-instruction multiple-data (MIMD)
  - > **Quantum dynamics (QD): data parallelism**  
Single-instruction multiple-data (SIMD)
- Hybrid multiscale/multiphysics applications
- Deterministic vs. stochastic (to solve intractable) applications
- Data + learning + visualization

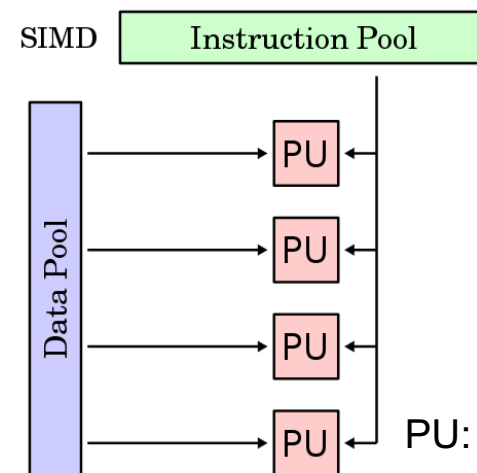
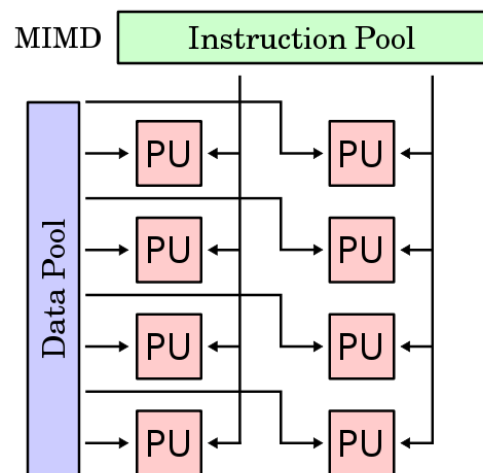

PU: processing unit

# The Landscape of Parallel Computing Research: A View from Berkeley

## 7 dwarfs (a dwarf is an algorithmic method that captures a pattern of computation and communication) + 6 combinatorial

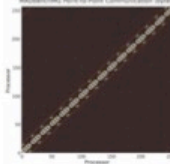
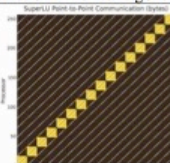
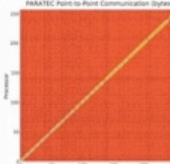
Dwarf	Description	Communication Pattern (Figure axes show processors 1 to 256, with black meaning no communication)	NAS Benchmark / Example HW
1. Dense Linear Algebra (e.g., BLAS [Blackford et al 2002], ScaLAPACK [Blackford et al 1996], or MATLAB [MathWorks 2006])	Data are dense matrices or vectors. (BLAS Level 1 = vector-vector; Level 2 = matrix-vector; and Level 3 = matrix-matrix.) Generally, such applications use unit-stride memory accesses to read data from rows, and strided accesses to read data from columns.	 The communication pattern of MadBench, which makes heavy use of ScaLAPACK for parallel dense linear algebra, is typical of a much broader class of numerical algorithms.	Block Triadiagonal Matrix, Lower Upper Symmetric Gauss-Seidel / Vector computers, Array computers
2. Sparse Linear Algebra (e.g., SpMV, OSKI [OSKI 2006], or SuperLU [Demmel et al 1999])	Data sets include many zero values. Data is usually stored in compressed matrices to reduce the storage and bandwidth requirements to access all of the nonzero values. One example is block compressed sparse row (BCSR). Because of the compressed formats, data is generally accessed with indexed loads and stores.	 SuperLU (communication pattern pictured above) uses the BCSR method for implementing sparse LU factorization.	Conjugate Gradient / Vector computers with gather/scatter
3. Spectral Methods (e.g., FFT [Cooley and Tukey 1965])	Data are in the frequency domain, as opposed to time or spatial domains. Typically, spectral methods use multiple butterfly stages, which combine multiply-add operations and a specific pattern of data permutation, with all-to-all communication for some stages and strictly local for others.	 PARATEC: The 3D FFT requires an all-to-all communication to implement a 3D transpose, which requires communication between every link. The diagonal stripe describes BLAS-3 dominated linear-algebra step required for orthogonalization.	Fourier Transform / DSPs, Zalink PDSP [Zarlink 2006]

In performance optimization

MD

QD

Monte Carlo

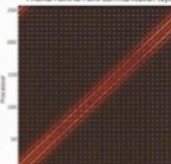
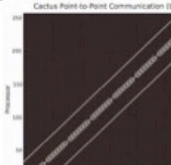
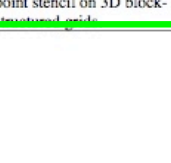
Dwarf	Description	Communication Pattern (Figure axes show processors 1 to 256, with black meaning no communication)	NAS Benchmark / Example HW
4. N-Body Methods (e.g., Barnes-Hut [Barnes and Hut 1986], Fast Multipole Method [Greengard and Rokhlin 1987])	Depends on interactions between many discrete points. Variations include particle-particle methods, where every point depends on all others, leading to an $O(N^2)$ calculation, and hierarchical particle methods, which combine forces or potentials from multiple points to reduce the computational complexity to $O(N \log N)$ or $O(N)$ .	 PMEMD's communication pattern is that of a particle mesh Ewald calculation.	(no benchmark) / GRAPE [Tokyo 2006], MD-GRAPE [IBM 2006]
5. Structured Grids (e.g., Cactus [Goodale et al 2003] or Lattice-Boltzmann Magnetohydrodynamics [LBMHD 2005])	Represented by a regular grid; points on grid are conceptually updated together. It has high spatial locality. Updates may be in place or between 2 versions of the grid. The grid may be subdivided into finer grids in areas of interest ("Adaptive Mesh Refinement"); and the transition between granularities may happen dynamically.	 Communication pattern for Cactus, a PDE solver using 7-point stencil on 3D block-structured grids.	Multi-Grid, Scalar Pentadiagonal / QCDOC [Edinburg 2006], BlueGeneL
6. Unstructured Grids (e.g., ABAQUS [ABAQUS 2006] or FIDAP [FLUENT 2006])	An irregular grid where data locations are selected, usually by underlying characteristics of the application. Data point location and connectivity of neighboring points must be explicit. The points on the grid are conceptually updated together. Updates typically involve multiple levels of memory reference indirection, as an update to any point requires first determining a list of neighboring points, and then loading values from those neighboring points.	 Cactus Point-to-Point Communication (static)	Unstructured Adaptive / Vector computers with gather/scatter, Tera Multi Threaded Architecture [Berry et al 2006]
7. Monte Carlo (e.g., Quantum Monte Carlo [Aspuru-Guzik et al 2005])	Calculations depend on statistical results of repeated random trials. Considered embarrassingly parallel.	Communication is typically not dominant in Monte Carlo methods.	Embarrassingly Parallel / NSF Teragrid

# CSCI653: Algorithms & Tools

---

---

- *Just one thing*: Divide-conquer-“recombine” (DCR) algorithm; it’s data locality!
- *Parallel computing = decomposition (who does what)*: Scalability analysis; performance optimization
- *Programming languages*: MPI (distributed memory) + OpenMP (shared memory) + CUDA|OpenMP4.5|SYCL (heterogeneous accelerator)



# Introduction to Parallel Computing

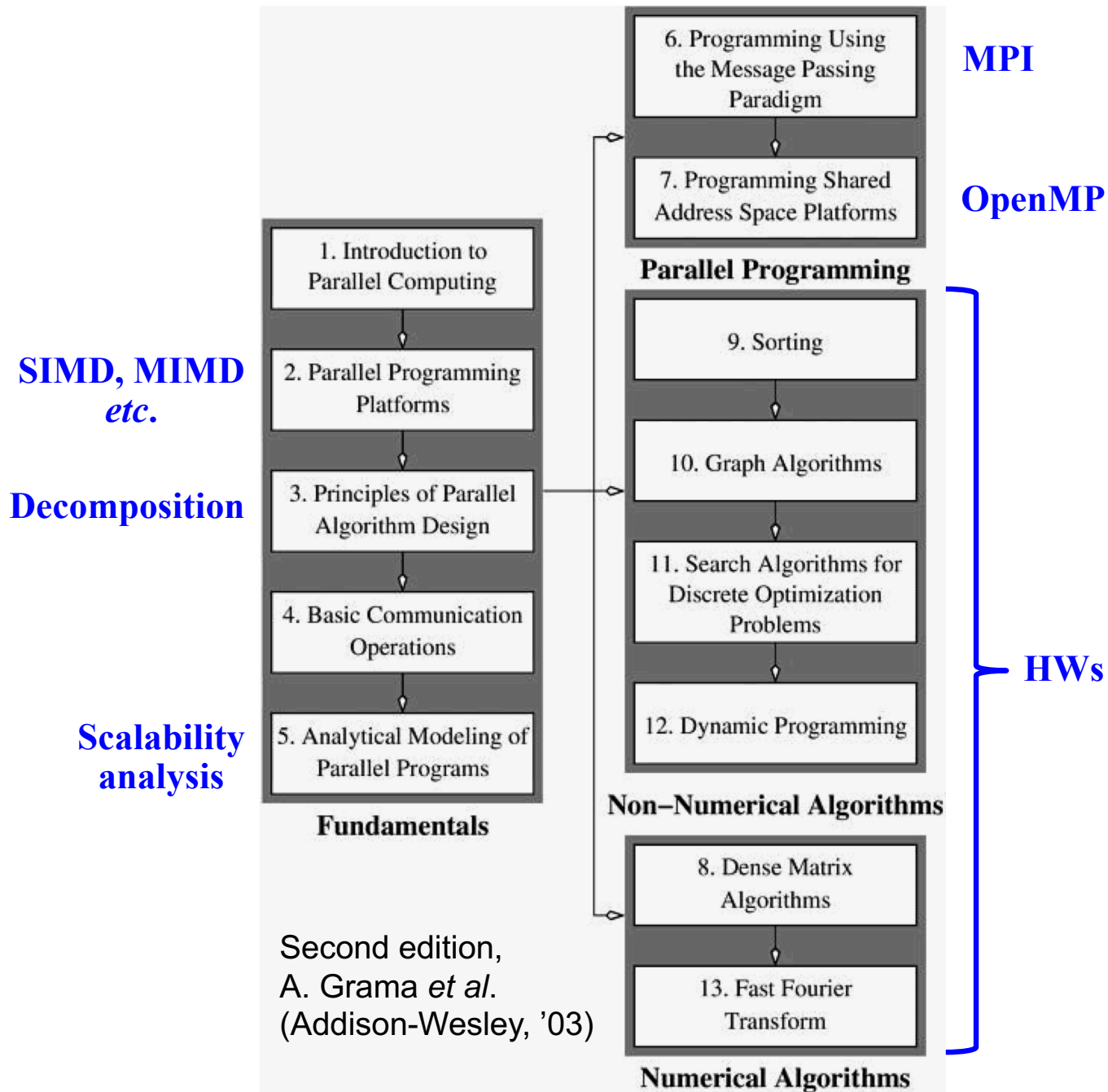

# High Performance Computing (HPC)

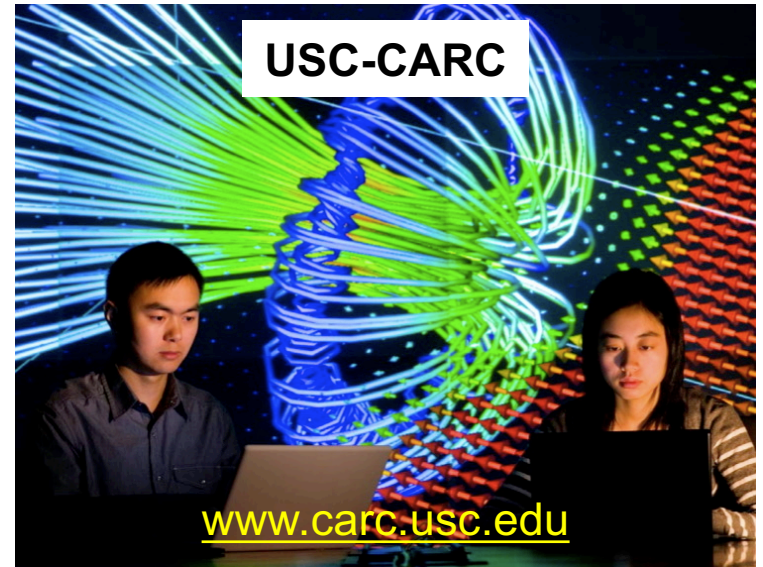
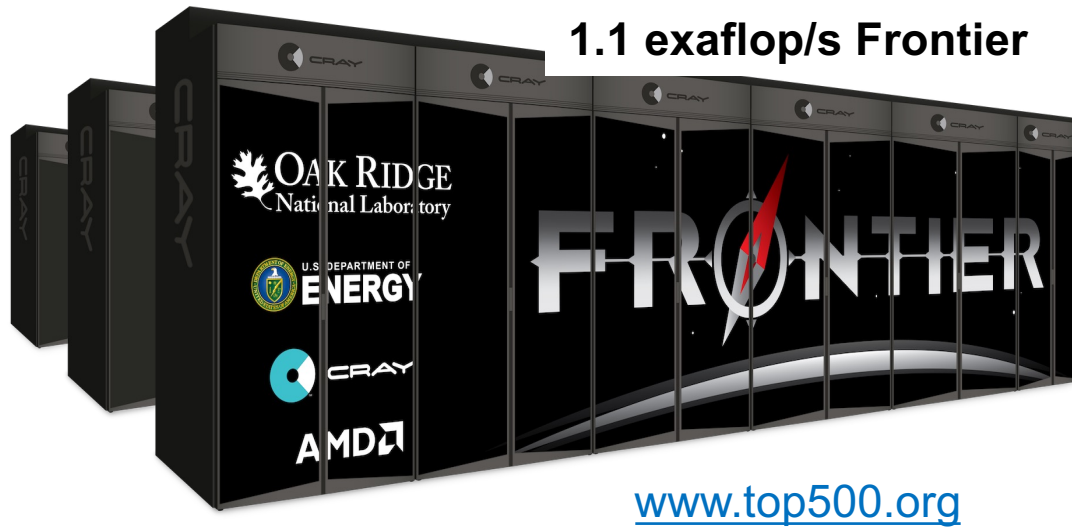

- **USC CARC (Center for Advanced Research Computing): 10,000+ CPU cores accelerated by GPUs**
- **USC ISI (Information Sciences Institute): 1,098-qubit D-Wave quantum computer**

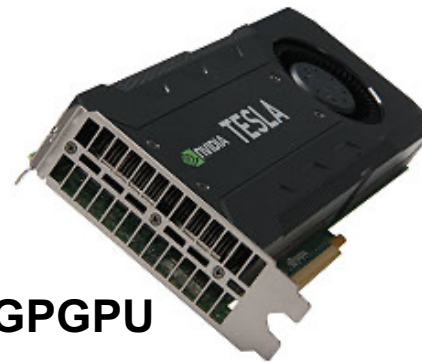

GPGPU

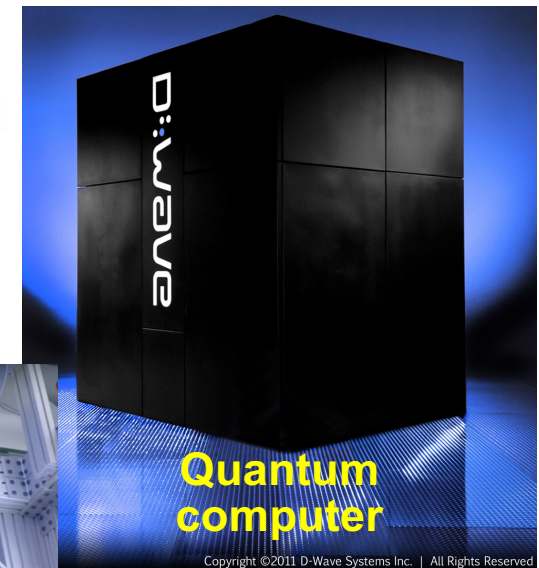

petaflop/s =  $10^{15}$  mathematical operations per second  
exaflop/s =  $10^{18}$  mathematical operations per second

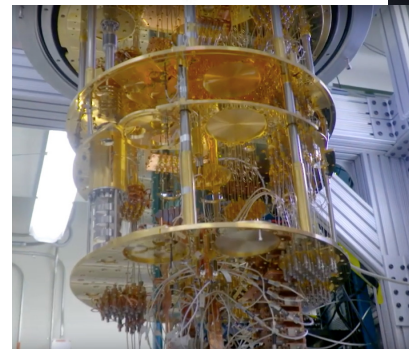

QPU

# Current & Future Supercomputing

- Won two DOE supercomputing awards to develop & deploy metascalable (“design once, scale on future platforms”) simulation algorithms (2017-2023)



Innovative & Novel Computational Impact on Theory & Experiment

**Title:** “Petascale Simulations for Layered Materials Genome”

**Principal Investigator:**

Aiichiro Nakano, University of Southern California

**Co-Investigator:**

Priya Vashishta, University of Southern California

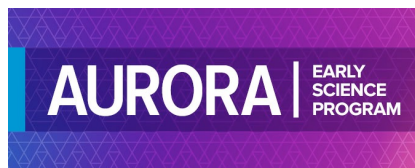
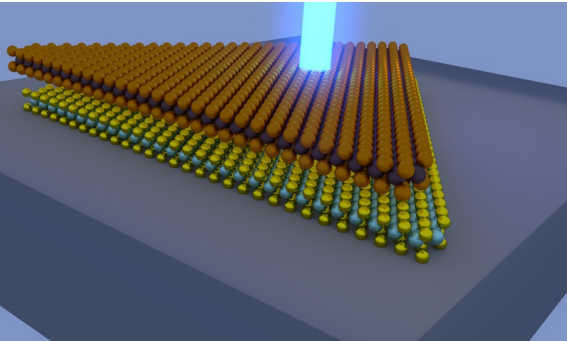

Early Science Projects for Aurora

Supercomputer Announced

Metascalable layered materials genome

*Investigator: Aiichiro Nakano, University of Southern California*

- Atomistic simulations on full 800K cores (pre-exascale)



786,432-core IBM Blue Gene/Q  
281,088-core Intel Xeon Phi



2 exaflop/s  
Intel Aurora (forthcoming)

exaflop/s =  $10^{18}$  mathematical operations per second

- One of the 10 initial simulation users of the next-generation DOE supercomputer



# CACS@Aurora in the Global Exascale Race

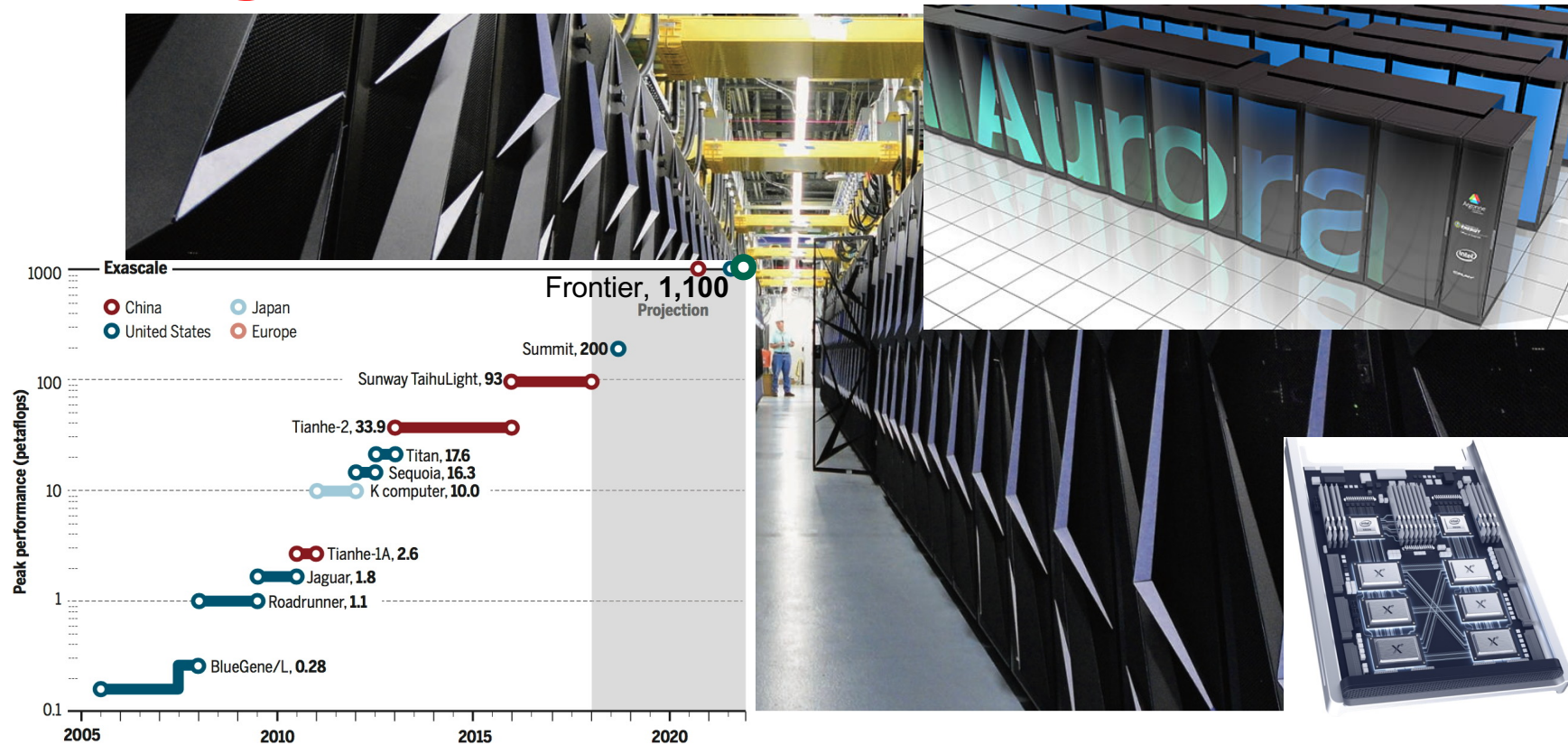

**SUPERCOMPUTING**

R. F. Service, *Science* **359**, 617 ('18)

## *Design for U.S. exascale computer takes shape*

Competition with China accelerates plans for next great leap in supercomputing power

By **Robert F. Service**

In 1957, the launch of the Sputnik satellite vaulted the Soviet Union to the lead in the space race and galvanized the United States. U.S. supercomputer researchers are today facing their own

Lemont, Illinois. That's 2 years earlier than planned. "It's a pretty exciting time," says Aiichiro Nakano, a physicist at the University of Southern California in Los Angeles who uses supercomputers to model materials made by layering stacks of atomic sheets like graphene.

pace reflects a change of strategy by DOE officials last fall. Initially, the agency set up a "two lanes" approach to overcoming the challenges of an exascale machine, in particular a potentially ravenous appetite for electricity that could require the output of a small nuclear plant.

Exa(peta)flop/s =  $10^{18}$  ( $10^{15}$ ) floating-point operations per second

# BES

# Exa-leadership

BASIC ENERGY SCIENCES

## EXASCALE REQUIREMENTS REVIEW

An Office of Science review sponsored jointly by  
Advanced Scientific Computing Research and Basic Energy Sciences

**16,661-atom QMD**

**Shimamura *et al.*,  
*Nano Lett.*  
14, 4090 ('14) QD**

**10<sup>9</sup>-atom RMD**

**Shekhar *et al.*,  
*Phys. Rev. Lett.*  
111, 184503 ('13)**

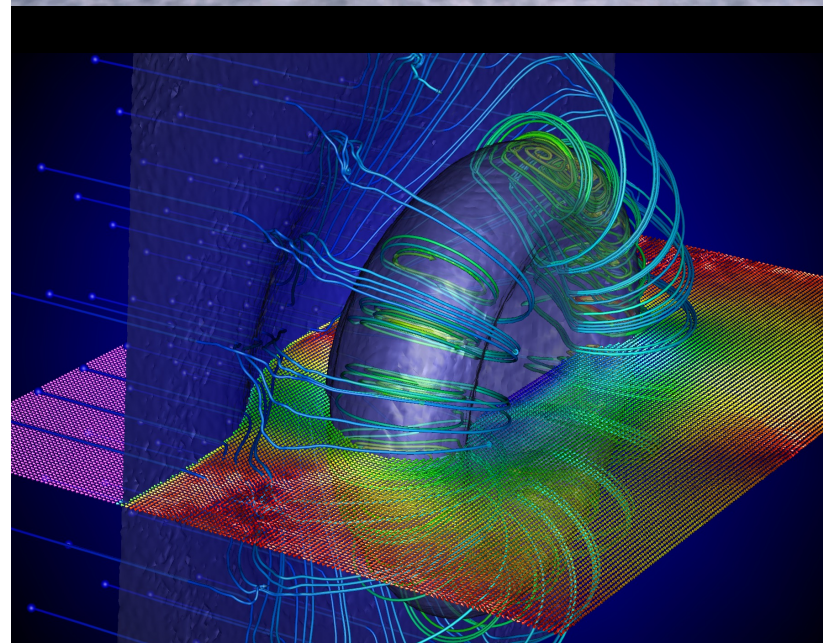
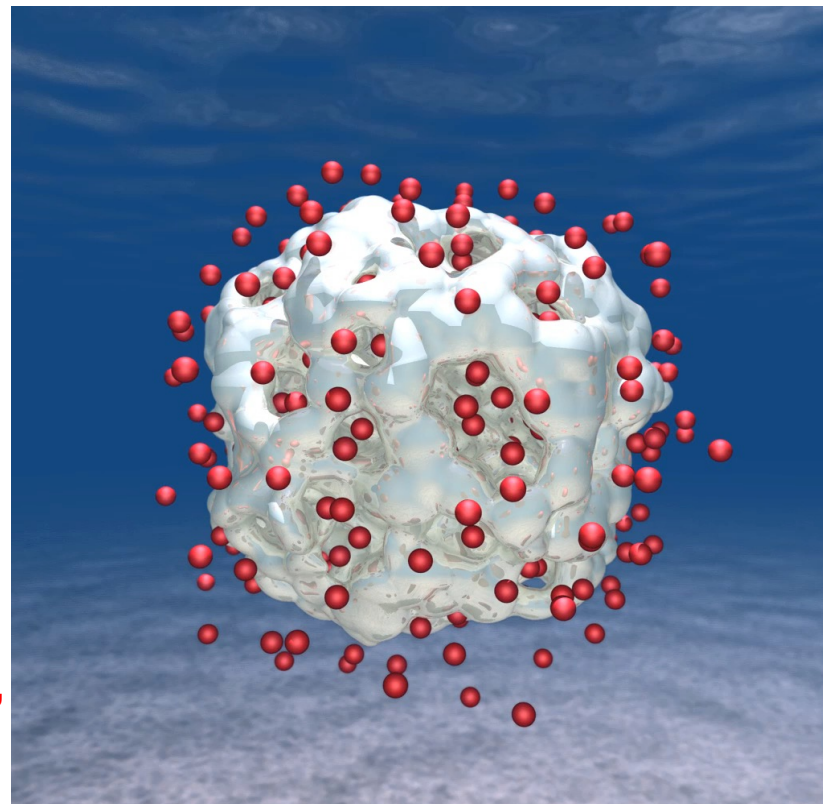

NOVEMBER 3-5, 2015

ROCKVILLE, MARYLAND



U.S. DEPARTMENT OF  
**ENERGY**

MD



# BES

## BASIC ENERGY SCIENCES

### EXASCALE REQUIREMENTS REVIEW

An Office of Science review sponsored jointly by  
Advanced Scientific Computing Research and Basic Energy Sciences

**16,661-atom QMD**

**Shimamura *et al.*,  
*Nano Lett.***

**14, 4090 ('14) QD**

**10<sup>9</sup>-atom RMD**

**Shekhar *et al.*,  
*Phys. Rev. Lett.***

**111, 184503 ('13)**

MD

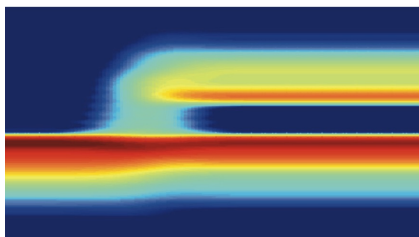
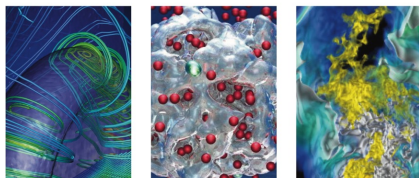
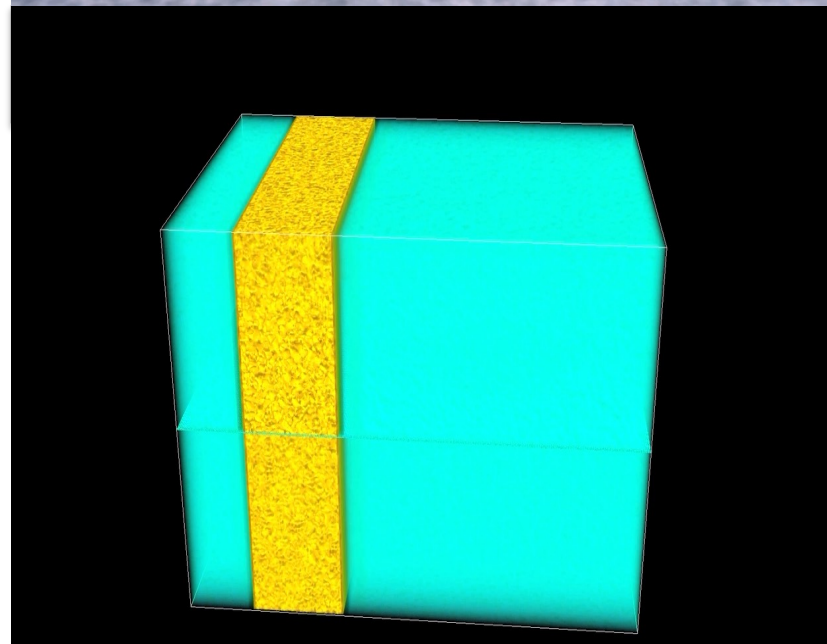
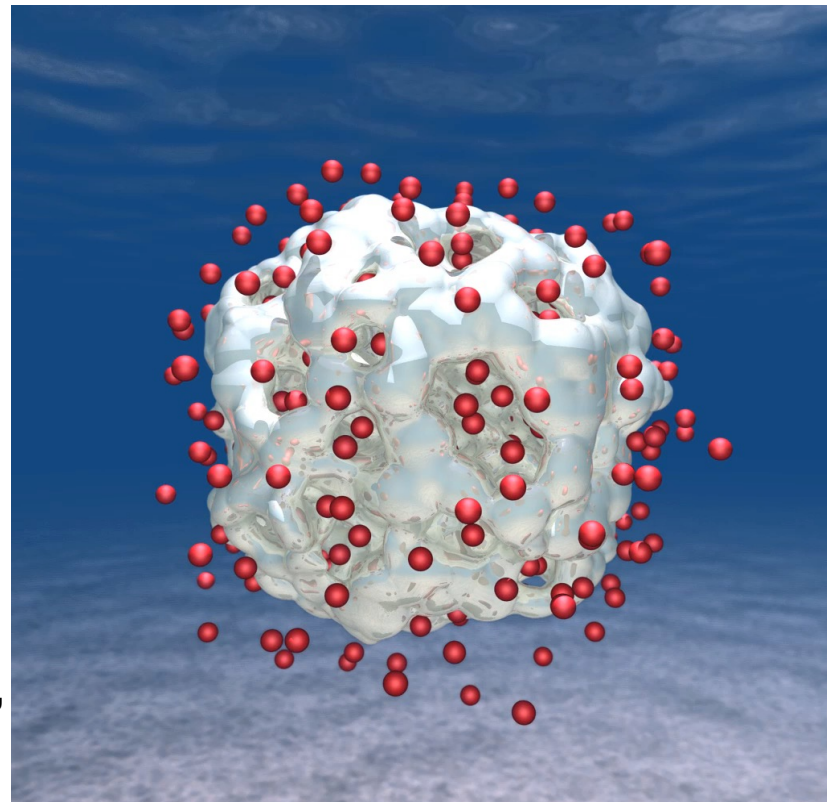

NOVEMBER 3-5, 2015

ROCKVILLE, MARYLAND



# Changing Computing Landscape for Science

## Postexascale Computing for Science



Compute Cambrian explosion



## Quantum Computing for Science

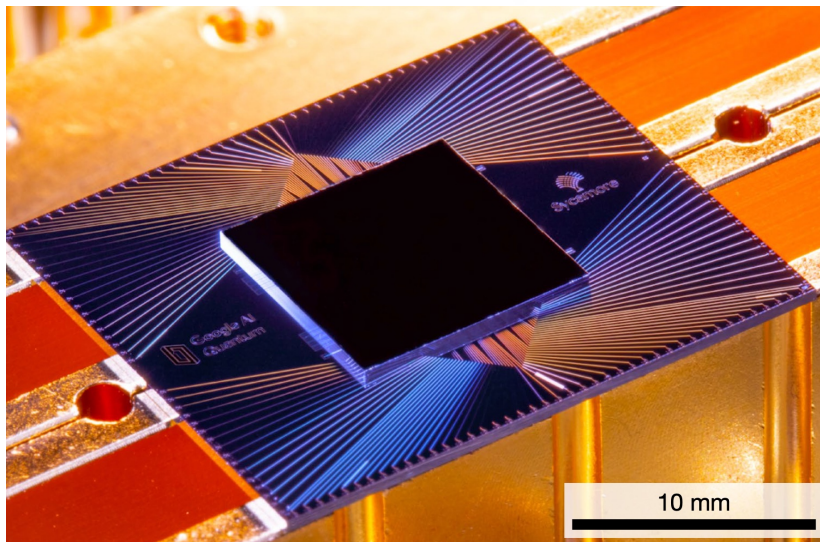

## AI for Science

### DOE readies multibillion- dollar AI push

U.S. supercomputing leader is the latest big backer in a globally crowded field

By **Robert F. Service**, in Washington, D.C.

*Science* **366**, 559 (Nov. 1, '19)



**Use all to advance science!**

# Glimpse of Compute Cambrian Explosion

---

## Track 1 – Hardware Architectures

8:30AM	Introduction	Vitali Morozov, ANL Kalyan Kumaran, ANL
9:00AM	The Oak Ridge Leadership Computing Facility's (OLCF's) Summit & Frontier Supercomputers	Tom Papatheodore, ORNL
9:30AM	Memory Coupled Compute: Innovating the future of HPC and AI	Samantika Sury, Samsung
10:00AM	<i>Break</i>	
10:30AM	Software-defined Machine Learning with Groq's Tensor Streaming Processor	Andrew Ling, Groq
11:00AM	Training Deep Learning Models on Habana Gaudi	Milind S. Pandit, Habana
11:30AM	SW/HW Innovations in Emerging DL Training Systems	Urmish Thakker, SambaNova
12:00PM	Graphcore IPUs: Accelerating Argonne's ML/AI Applications	Richard Bohl, Graphcore
12:30PM	<i>Lunch</i>	
1:30PM	Accelerating AI and HPC for science at wafer-scale with Cerebras Systems	Andy Hock, Cerebras
2:00PM	An overview of Argonne's Aurora Exascale Supercomputer and its Programming Models	Servesh Muralidharan, ANL
2:30PM	Considerations for programming Slingshot at scale	Keith D. Underwood, HPE
3:00PM	Quantum computing trends	Yuri Alexeev, ANL

<https://extremecomputingtraining.anl.gov/agenda-2022/>

# A Metascalable Dwarf

A metascalable (or “design once, scale on new architectures”) parallel-computing framework for broad applications (*e.g.* equation solvers, constrained optimization, search, visualization and graphs)

- **Divide-conquer-“recombine” (DCR) algorithms based on spatial locality to design linear-scaling algorithms**
- **Space-time-ensemble parallel (STEP) approach based on temporal locality to predict long-time dynamics**
- **Tunable hierarchical cellular decomposition (HCD) to map these scalable algorithms onto hardware**

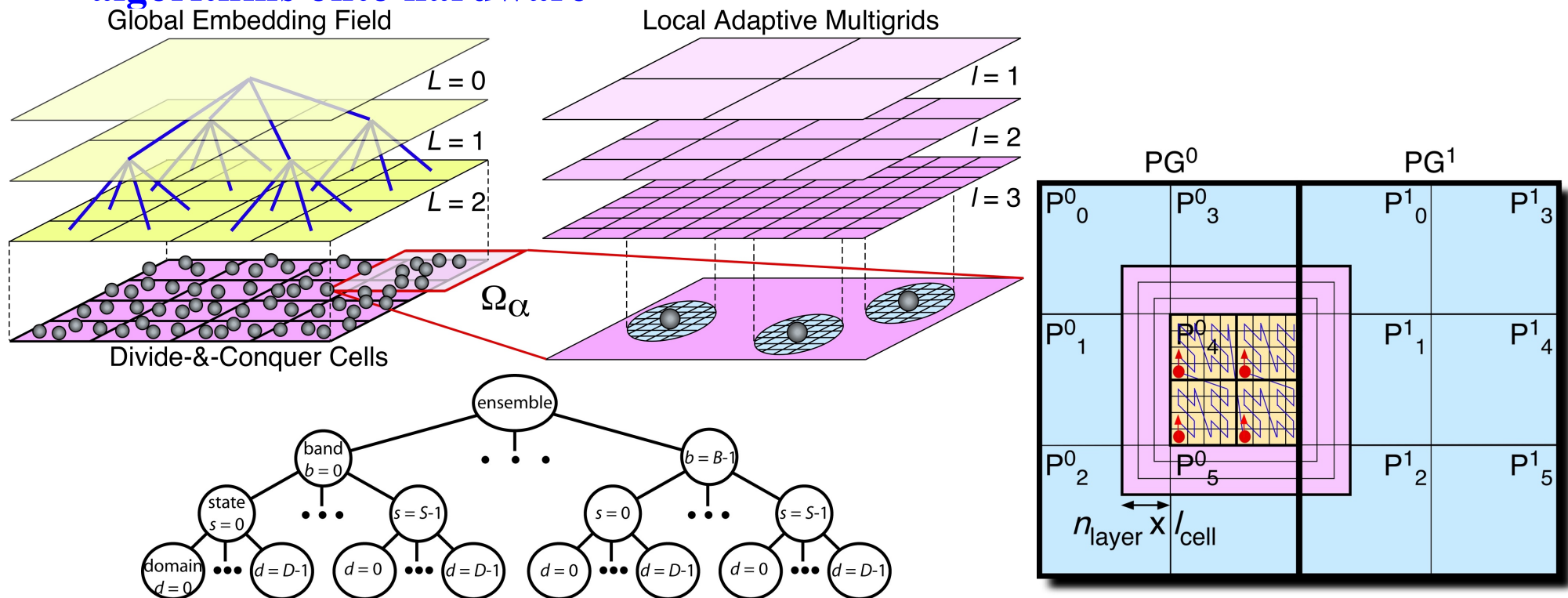

# Divide-Conquer-Recombine (DCR) Engines

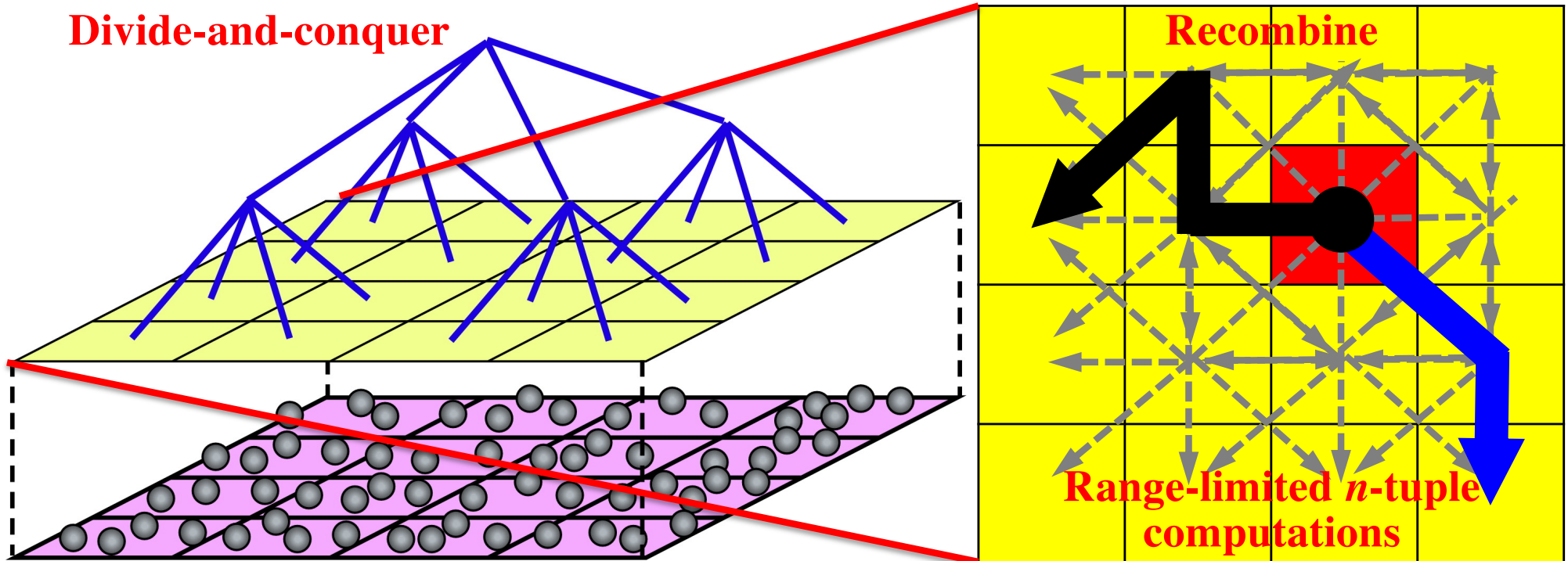

M. Kunaseth et al., ACM/IEEE SC13

- **Lean divide-&-conquer density functional theory (LDC-DFT) algorithm minimizes the prefactor of  $O(N)$  computational cost**  
F. Shimojo et al., *J. Chem. Phys.* **140**, 18A529 ('14); S. Tiwari et al., *HPCAsia Best Paper* ('20)
- **Extended-Lagrangian reactive molecular dynamics (XRMD) algorithm eliminates the speed-limiting charge iteration**  
K. Nomura et al., *Comput. Phys. Commun.* **192**, 91 ('15); K. Liu et al., *IEEE/ACM ScaIA18*  
N. Romero et al., *IEEE Computer* **48(11)**, 33 ('15)



# Hierarchical Parallel Computing

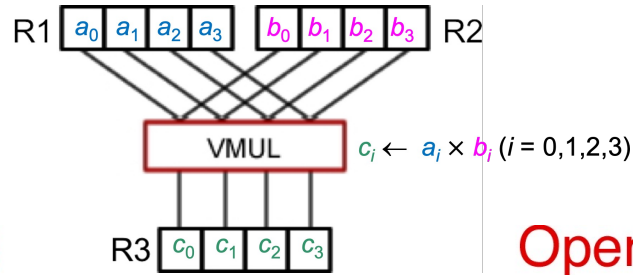

SIMD

OpenMP

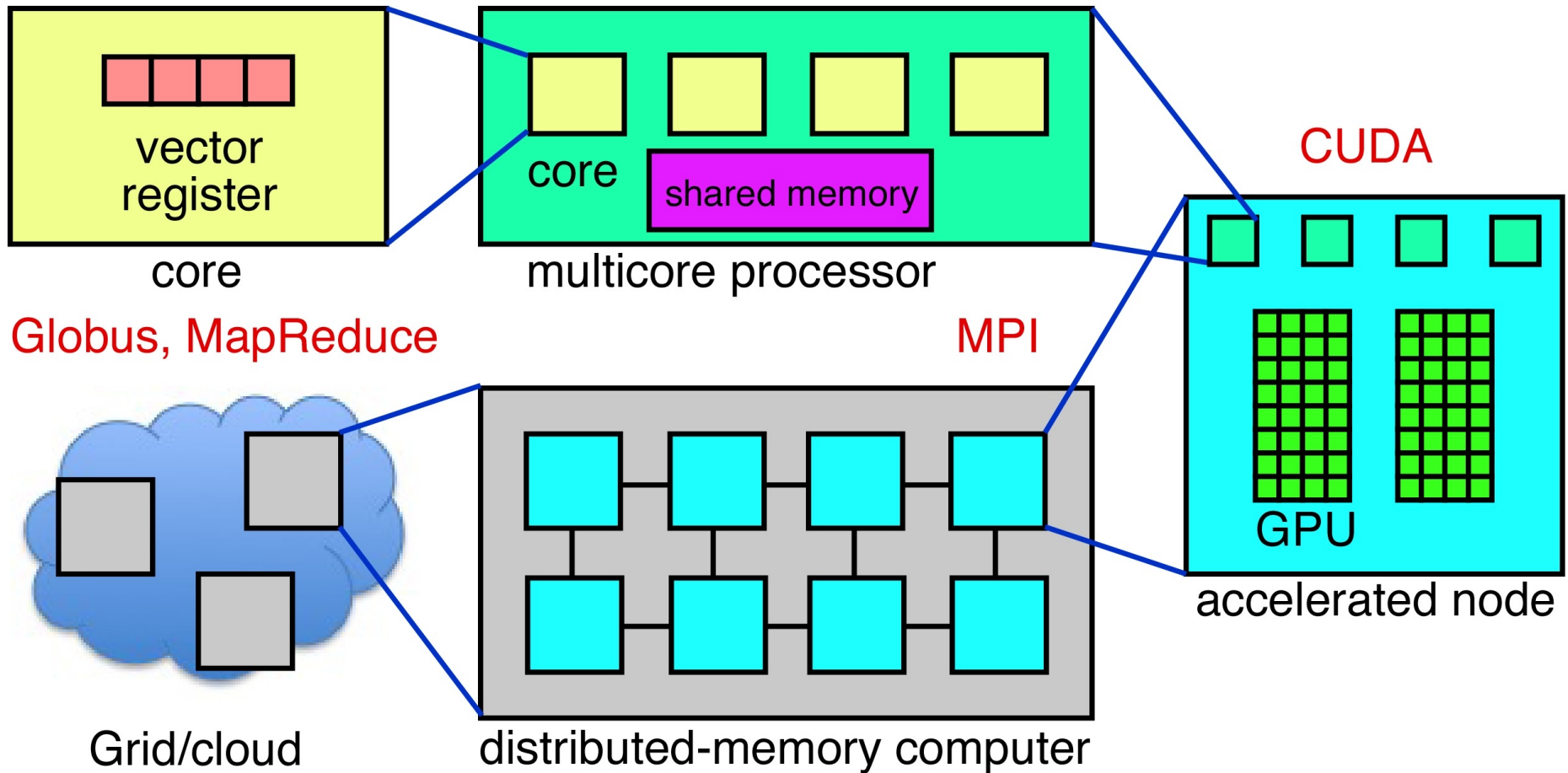

Q: Think forward 10 years. How many of you predict that most of our top HPC systems will have the following architectural features?

- a) X86 multicore CPU
- b) GPU
- c) FPGA/Reconfigurable processor
- d) Neuromorphic processor
- e) Deep learning processor
- f) Quantum processor
- g) RISC-V processor
- h) Some new unknown processor
- i) All/some of the above in one SoC



Q: Now imagine you are building a new application with ~3M LOC and 20 team members over the next 10 years. What on-node programming model/system do you use?

### What X in MPI+X?

- a) C, C++, Fortran
- b) C++ templates, policies, etc (e.g., AMP, Kokkos, RAJA, )
- c) CUDA, cu\*\*\*, HIP
- d) OpenCL, SYCL
- e) OpenMP or OpenACC
- f) R, Python, Matlab, etc
- g) A Domain Specific Language (e.g., Claw, PySL)
- h) A Domain Specific Framework (e.g., PetSc)
- i) Some new unknown programming approach
- j) All/some of the above

# Now What? Physics in 100 Years

---

- Increasingly, the development of algorithms will become a central focus of theoretical physics. ... Triumphs of creative understanding such as universality (suppression of irrelevant details), symmetry (informed iteration), and topology (emergence of discrete from continuous) are preadapted to **algorithmic thinking**.
- The work of designing algorithms can be considered as a special form of teaching, aimed at extremely clever but literal-minded and inexperienced students—that is, computers—who cannot deal with vagueness. At present those students are poorly motivated and incurious, but those faults are curable. **Within 100 years they (computers) will become the colleagues and ultimately the successors of their human teachers, with a distinctive style of thought adapted to their talents.**
- Two developments will be transformative: **naturalized artificial intelligence and expanded sensoria.**

F. Wilczek, *Phys. Today* **69(4)**, 32 ('16)

<https://aiichironakano.github.io/cs653/Wilczek-PhysicsIn100Years-PhysToday16.pdf>

**To sum:**

**HPC for science (previous CSCI 653)**



**AI + quantum + post-exa nexus:  
Survive the compute Cambrian explosion  
by finding your niche!**

**How?**

# Use Final Project Publications!

Computer Physics Communications 219 (2017) 246–254



Contents lists available at ScienceDirect

Computer Physics Communications

journal homepage: [www.elsevier.com/locate/cpc](http://www.elsevier.com/locate/cpc)

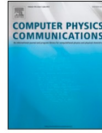

A derivation and scalable implementation of the synchronous parallel kinetic Monte Carlo method for simulating long-time dynamics



[Hye Suk Byun](#)<sup>a</sup>, Mohamed Y. El-Naggar<sup>a,b,c</sup>, Rajiv K. Kalia<sup>a,d,e,f</sup>, Aiichiro Nakano<sup>a,b,d,e,f,\*</sup>, Priya Vashishta<sup>a,d,e,f</sup>

Computer Physics Communications 247 (2020) 106873

sDMD: An open source program for discontinuous molecular dynamics simulation of protein folding and aggregation<sup>☆</sup>

[Size Zheng](#)<sup>a,\*</sup>, Leili Javidpour<sup>b</sup>, Muhammad Sahimi<sup>c</sup>, Katherine S. Shing<sup>c</sup>, Aiichiro Nakano<sup>c</sup>

Computer Physics Communications 239 (2019) 265–271



Contents lists available at ScienceDirect

Computer Physics Communications

journal homepage: [www.elsevier.com/locate/cpc](http://www.elsevier.com/locate/cpc)



PAR<sup>2</sup>: Parallel Random Walk Particle Tracking Method for solute transport in porous media<sup>☆</sup>



[Calogero B. Rizzo](#)<sup>a,\*</sup>, Aiichiro Nakano<sup>b</sup>, Felipe P.J. de Barros<sup>a</sup>

Geophysical Research Letters 48, e2020GL091681 (2021)

Molecular Dynamics Simulations of Dielectric Breakdown of Lunar Regolith: Implications for Water Ice Formation on Lunar Surface

[Ziyu Huang](#)<sup>1</sup>, Ken-ichi Nomura<sup>2</sup>, Aiichiro Nakano<sup>3</sup> , and Joseph Wang<sup>1</sup> 

Computational Materials Science 173 (2020) 109429



Contents lists available at ScienceDirect

Computational Materials Science

journal homepage: [www.elsevier.com/locate/commatsci](http://www.elsevier.com/locate/commatsci)

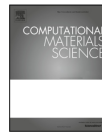





Boltzmann machine modeling of layered MoS<sub>2</sub> synthesis on a quantum annealer



[Jeremy Liu](#)<sup>a,b</sup>, [Ankith Mohan](#)<sup>a</sup>, Rajiv K. Kalia<sup>c</sup>, Aiichiro Nakano<sup>c</sup>, Ken-ichi Nomura<sup>c,\*</sup>, Priya Vashishta<sup>c</sup>, Ke-Thia Yao<sup>a</sup>

Quantum Science & Technology 6, 014007 (2021)

Domain-specific compilers for dynamic simulations of quantum materials on quantum computers

Lindsay Bassman<sup>5,1</sup> , [Sahil Gulania](#)<sup>2</sup>, Connor Powers<sup>1</sup> , Rongpeng Li<sup>3</sup>, Thomas Linker<sup>1</sup> , Kuang Liu<sup>1</sup>, T K Satish Kumar<sup>4</sup>, Rajiv K Kalia<sup>1</sup>, Aiichiro Nakano<sup>1</sup>  and Priya Vashishta<sup>1</sup> 

# Journal Cover



Table-of-content image

*Journal of Chemical Information and Modeling* **61**, 2175-2186 (2021)

Dielectric polymer property prediction using recurrent neural networks with optimizations

Antonina L. Nazarova, L. Yang, K. Liu, A. Mishra, R. K. Kalia, K. Nomura, A. Nakano, P. Vashishta, and P. Rajak

**VLA-SMILES: Variable-Length-Array SMILES Descriptors in Neural Network-Based QSAR Modeling**

Antonina L. Nazarova<sup>1\*,†</sup> and Aiichiro Nakano<sup>2,\*</sup>

*Journal of Machine Learning and Knowledge Extraction* **4**, 715 (2022)



# What's New

---

---

## Special Issue in *Journal of Chemical Physics*



### High Performance Computing in Chemical Physics

**Submission Deadline:** January 15, 2023

The push towards exascale computing hardware has led to supercomputers with remarkable computing capacity. At the same time, there are also dramatic increases in the computing power of single workstations,...

[MORE INFORMATION →](#)

[CONTRIBUTE TO THIS SPECIAL TOPIC →](#)

## **IPAM Program: *New Mathematics for the Exascale: Applications to Materials Science***

**March 13 – June 16, 2023**

***Institute for Pure & Applied Mathematics, UCLA***



**Self-introduction:  
Recruit a team member!  
(Team project is encouraged.)**