

# Molecular Dynamics Basics

Basics of the molecular-dynamics (MD) method<sup>1-3</sup> are described, along with corresponding data structures in program, `md.c`.

## Newton's Second Law of Motion

### TRAJECTORY, COORDINATE, AND ACCELERATION

- Physical system = a set of atomic coordinates:

$$\{\vec{r}_i = (x_i, y_i, z_i) \mid x_i, y_i, z_i \in \mathfrak{R}, i = 0, \dots, N-1\},$$

where  $\mathfrak{R}$  is the set of real numbers (in the program, represented by a double precision variable) and we use a vector notation,  $\vec{\phantom{x}}$ .

(Data structures in `md.c`)

`int nAtom`:  $N$ , the number of atoms.

`NMAX`: Maximum number of atoms that can be handled by the program.

`double r[NMAX][3]`: `r[i][0]`, `r[i][1]`, and `r[i][2]` are the  $x$ ,  $y$ , and  $z$  coordinates of the  $i$ -th atom, where  $i = 0, \dots, N-1$ .

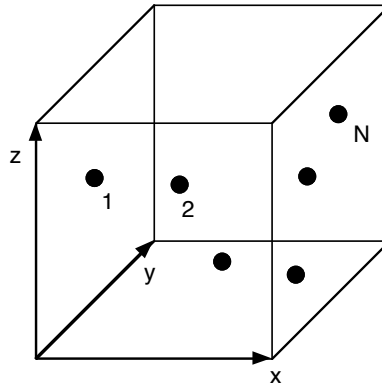

- Trajectory**: A mapping from time to a point in the 3-dimensional space,  $t \in \mathfrak{R} \mapsto \vec{r}_i(t) \in \mathfrak{R}^3$ . In fact, a trajectory of an  $N$ -atom system is regarded as a curve in  $3N$ -dimensional space. A point on the curve is then specified by a  $3N$ -element vector,  $\vec{r}^N = (x_0, y_0, z_0, x_1, y_1, z_1, \dots, x_{N-1}, y_{N-1}, z_{N-1})$ .

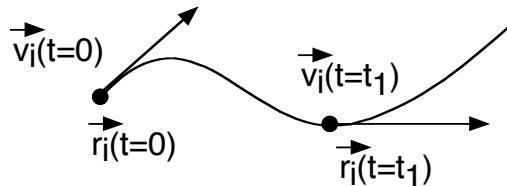

- Velocity**: Short-time limit of an average speed (how fast and in which direction the particle is moving),

$$\vec{v}_i(t) = \dot{\vec{r}}_i(t) = \frac{d\vec{r}}{dt} \equiv \lim_{\Delta \rightarrow 0} \frac{\vec{r}_i(t + \Delta) - \vec{r}_i(t)}{\Delta}.$$

`double rv[NMAX][3]`: `rv[i][0]`, `rv[i][1]`, and `rv[i][2]` are the  $x$ ,  $y$ , and  $z$  components of the velocity vector,  $\vec{v}_i$ , of the  $i$ -th atom.

- Acceleration**: Rate at which a velocity changes (whether the particle is accelerating or decelerating),

$$\vec{a}_i(t) = \ddot{\vec{r}}_i(t) = \frac{d^2\vec{r}}{dt^2} = \frac{d\vec{v}_i}{dt} \equiv \lim_{\Delta \rightarrow 0} \frac{\vec{v}_i(t+\Delta) - \vec{v}_i(t)}{\Delta}.$$

double ra[NMAX][3]: ra[i][0], ra[i][1], and ra[i][2] are the x, y, and z components of the acceleration vector,  $\vec{a}_i$ , of the  $i$ -th atom.

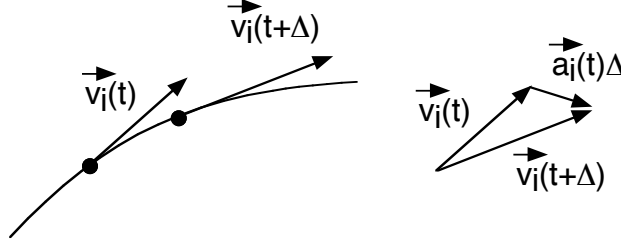

The acceleration of a particle can be estimated from three consecutive positions on its trajectory separated by small time increments:

$$\begin{aligned} \vec{a}_i(t) &= \lim_{\Delta \rightarrow 0} \frac{\vec{v}_i(t + \Delta/2) - \vec{v}_i(t - \Delta/2)}{\Delta} \\ &= \lim_{\Delta \rightarrow 0} \frac{\frac{\vec{r}_i(t + \Delta) - \vec{r}_i(t)}{\Delta} - \frac{\vec{r}_i(t) - \vec{r}_i(t - \Delta)}{\Delta}}{\Delta} \\ &= \lim_{\Delta \rightarrow 0} \frac{\vec{r}_i(t + \Delta) - 2\vec{r}_i(t) + \vec{r}_i(t - \Delta)}{\Delta^2} \end{aligned}$$

## NEWTON'S EQUATION

Newton's equation states that the acceleration of a particle is proportional to the force acting on the particle,

$$m\ddot{\vec{r}}_i(t) = \vec{F}_i(t),$$

where  $m$  is the mass of the particle. For a heavier particle, the same force causes less acceleration (or deceleration).

- Initial value problem: Given initial particle positions and velocities,  $\{(\vec{r}_i(0), \vec{v}_i(0)) | i = 1, \dots, N\}$ , obtain those at later times,  $\{(\vec{r}_i(t), \vec{v}_i(t)) | i = 1, \dots, N; t \geq 0\}$ . Note that both positions and velocities must be specified in order to predict future trajectories.

## Potential Energy

We consider forces which are derived from a potential energy,  $V(\vec{r}^N)$ , which is a function of all atomic positions.

$$\vec{F}_k = -\frac{\partial}{\partial \vec{r}_k} V(\vec{r}^N) = -\left( \frac{\partial V}{\partial x_k}, \frac{\partial V}{\partial y_k}, \frac{\partial V}{\partial z_k} \right).$$

Here **partial derivative** is defined as

$$\frac{\partial V}{\partial x_k} = \lim_{h \rightarrow 0} \frac{V(x_0, y_0, z_0, \dots, x_k + h, y_k, z_k, \dots, x_{N-1}, y_{N-1}, z_{N-1}) - V(x_0, y_0, z_0, \dots, x_k, y_k, z_k, \dots, x_{N-1}, y_{N-1}, z_{N-1})}{h},$$

i.e., what is the rate of change in  $V$  when we slightly change one coordinate of an atom while keeping all the other coordinates fixed.

## LENNARD-JONES POTENTIAL

To model certain materials such as neon and argon liquids, the Lennard-Jones potential is often used by scientists:

$$V(\vec{r}^N) = \sum_{i < j} u(r_{ij}) = \sum_{i=0}^{N-2} \sum_{j=i+1}^{N-1} u(|\vec{r}_{ij}|)$$

where  $\vec{r}_{ij} = \vec{r}_i - \vec{r}_j$  is the relative position vector between atoms  $i$  and  $j$ , and

$$u(r) = 4\epsilon \left[ \left( \frac{\sigma}{r} \right)^{12} - \left( \frac{\sigma}{r} \right)^6 \right].$$

• Physical meaning of the potential: An atom consists of a nucleus and electrons surrounding it. Two atoms interact with each other in the following ways.

- > Short-range repulsion (the first term): the Pauli exclusion principle states that electrons cannot occupy the same position, resulting in repulsion between the atoms. Note that for  $r \rightarrow 0$ , this term is dominant.

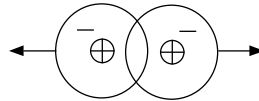
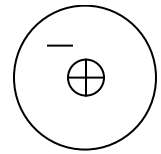

- > Long-range attraction (the second term): Electrons around nuclei polarize (change distribution), creating electrostatic attraction between atoms. Note that for  $r \rightarrow \infty$ , this term becomes dominant.

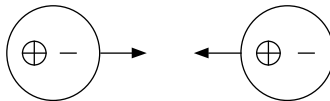

• For Argon atoms,

- >  $m = 6.6 \times 10^{-23}$  gram
- >  $\epsilon = 1.66 \times 10^{-14}$  erg (erg = gram•cm<sup>2</sup>/(second<sup>2</sup>) is a unit of energy)
- >  $\sigma = 3.4 \times 10^{-8}$  cm

\* Don't program with these numbers (in the CGS unit); it will cause floating-point under- or overflows.

## NORMALIZATION

• We introduce normalized coordinates,  $\vec{r}'_i$ , potential energy,  $V'$ , and time,  $t'$ , that are dimensionless and are defined as follows.

$$\begin{cases} \vec{r}_i = \vec{r}'_i \sigma = 3.4 \times 10^{-8} [\text{cm}] \times \vec{r}'_i \\ V = V' \epsilon = 1.66 \times 10^{-14} [\text{erg}] \times V' \\ t = \sigma \sqrt{m / \epsilon} t' = 2.2 \times 10^{-12} [\text{sec}] \times t' \end{cases}$$

With these substitutions, Newton's equation becomes

$$m \frac{\epsilon}{m \sigma^2} \sigma \frac{d^2 \vec{r}'_i}{dt'^2} = - \frac{\epsilon}{\sigma} \frac{\partial V'}{\partial \vec{r}'_i}.$$

\* In the derivation above, note that

$$\begin{aligned}
m \frac{d^2 \vec{r}_i}{dt^2} &= m \lim_{\Delta \rightarrow 0} \frac{\vec{r}_i(t + \Delta) - 2\vec{r}_i(t) + \vec{r}_i(t - \Delta)}{\Delta^2} \\
&= m \lim_{\Delta \rightarrow 0} \frac{\sigma [\vec{r}'_i(t + \Delta) - 2\vec{r}'_i(t) + \vec{r}'_i(t - \Delta)]}{[\sigma \sqrt{m/\epsilon}]^2 (\Delta')^2}
\end{aligned}$$

In summary, the normalized Newton's equation for atoms interacting with the Lennard-Jones potential is given below. (From now on, we always use normalized variables, and omit primes.)

$$\begin{aligned}
\frac{d^2 \vec{r}_i}{dt^2} &= -\frac{\partial V}{\partial \vec{r}_i} = \vec{a}_i \\
V(\vec{r}^N) &= \sum_{i < j} u(r_{ij}) \\
u(r) &= 4 \left( \frac{1}{r^{12}} - \frac{1}{r^6} \right)
\end{aligned}$$

The figure in the right shows the normalized Lennard-Jones potential,  $u(r)$ , as a function of interatomic distance,  $r$ . The distance,  $r_0$ , at which the potential takes its minimum value,  $u(r_0)$ , is obtained as follows.

$$\begin{aligned}
\left. \frac{du}{dr} \right|_{r=r_0} &= 0 \Rightarrow r_0 = 2^{1/6} \approx 1.12 \\
u(r_0) &= 4 \left( \frac{1}{2^{12/6}} - \frac{1}{2^{6/6}} \right) = -1
\end{aligned}$$

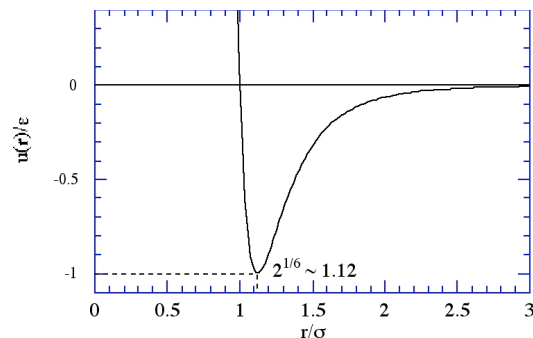

Figure: Lennard-Jones potential.

## ANALYTIC FORMULA FOR FORCES

$$\vec{a}_k = -\frac{\partial}{\partial \vec{r}_k} \sum_{i < j} u(r_{ij}) = -\sum_{i < j} \frac{\partial r_{ij}}{\partial \vec{r}_k} \frac{du}{dr_{ij}}$$

Let's evaluate the two factors in the above expression:

$$\begin{aligned}
1. \quad \frac{\partial r_{ij}}{\partial \vec{r}_k} &= \left( \frac{\partial}{\partial x_k}, \frac{\partial}{\partial y_k}, \frac{\partial}{\partial z_k} \right) \sqrt{(x_i - x_j)^2 + (y_i - y_j)^2 + (z_i - z_j)^2} \\
&= \frac{(2(x_i - x_j), 2(y_i - y_j), 2(z_i - z_j))}{2\sqrt{(x_i - x_j)^2 + (y_i - y_j)^2 + (z_i - z_j)^2}} (\delta_{ik} - \delta_{jk}) \\
&= \frac{\vec{r}_{ij}}{r_{ij}} (\delta_{ik} - \delta_{jk}) \\
&\left( \because \frac{d}{dx} [f(x)]^{1/2} = \frac{1}{2} [f(x)]^{-1/2} \frac{df}{dx} \right)
\end{aligned}$$

$$\begin{aligned}
2. \quad \frac{du}{dr} &= 4 \left( -\frac{12}{r^{13}} + \frac{6}{r^7} \right) = -\frac{48}{r} \left( \frac{1}{r^{12}} - \frac{1}{2r^6} \right) \\
&\left( \because \frac{d}{dr} r^{-n} = -nr^{-n-1} \right)
\end{aligned}$$

In the first result,

$$\delta_{ik} = \begin{cases} 1 & (i = k) \\ 0 & (i \neq k) \end{cases}$$

is called Kronecker's delta expression.

Substituting these two results back into the expression for  $\vec{a}_k$ , we obtain

$$\vec{a}_k = \sum_{i < j} \vec{r}_{ij} \left( -\frac{1}{r} \frac{du}{dr} \right)_{r=r_{ij}} (\delta_{ik} - \delta_{jk})$$

where

$$-\frac{1}{r} \frac{du}{dr} = \frac{48}{r^2} \left( \frac{1}{r^{12}} - \frac{1}{2r^6} \right)$$

## Summary of Molecular-Dynamics Equation System

Given initial atomic positions and velocities,  $\{(\vec{r}_i(0), \vec{v}_i(0)) | i=1, \dots, N\}$ , obtain those at later times,  $\{(\vec{r}_i(t), \vec{v}_i(t)) | i=1, \dots, N; t \geq 0\}$ , by integrating the following differential equation:

$$\ddot{\vec{r}}_k(t) = \vec{a}_k(t) = \sum_{i < j} \vec{r}_{ij}(t) \left( -\frac{1}{r} \frac{du}{dr} \right)_{r=r_{ij}(t)} (\delta_{ik} - \delta_{jk})$$

where

$$-\frac{1}{r} \frac{du}{dr} = \frac{48}{r^2} \left( \frac{1}{r^{12}} - \frac{1}{2r^6} \right)$$

The sum over  $i$  and  $j$  to evaluate the acceleration is implemented in a program as follows:

for  $i = 1$  to  $N$ ,  $\vec{a}_i = 0$ ,

for  $i = 1$  to  $N-1$

for  $j = i+1$  to  $N$

compute  $\vec{\alpha} = \vec{r}_{ij} \left( -\frac{1}{r} \frac{du}{dr} \right)_{r=|\vec{r}_{ij}|}$

$\vec{a}_i += \vec{\alpha}$

$\vec{a}_j -= \vec{\alpha}$

## Discretization

We need to discretize the trajectories in order to solve the problem on a computer: Instead of considering

$$(\vec{r}_i(t), \vec{v}_i(t)) \text{ for } t \geq 0$$

for continuous time, we consider a sequence of states

$$(\vec{r}_i(0), \vec{v}_i(0)) \mapsto (\vec{r}_i(\Delta), \vec{v}_i(\Delta)) \mapsto (\vec{r}_i(2\Delta), \vec{v}_i(2\Delta)) \mapsto \dots$$

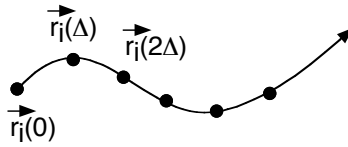

The question is: How to predict the next state,  $(\vec{r}_i(t + \Delta), \vec{v}_i(t + \Delta))$ , from the current state,  $(\vec{r}_i(t), \vec{v}_i(t))$ .

double DeltaT:  $\Delta$  in md.c.

## VERLET DISCRETIZATION

Let's apply the Taylor expansion

$$f(x_0 + h) = \sum_{n=0}^{\infty} \frac{h^n}{n!} \left. \frac{d^n f}{dx^n} \right|_{x=x_0} = f(x_0) + h \left. \frac{df}{dx} \right|_{x=x_0} + \frac{h^2}{2} \left. \frac{d^2 f}{dx^2} \right|_{x=x_0} + \frac{h^3}{3!} \left. \frac{d^3 f}{dx^3} \right|_{x=x_0} + \dots,$$

which predicts a function value at a distant point,  $x_0+h$ , from derivatives at  $x_0$ , to an atomic coordinate.

$$\begin{aligned} \vec{r}_i(t + \Delta) &= \vec{r}_i(t) + \vec{v}_i(t)\Delta + \frac{1}{2}\vec{a}_i(t)\Delta^2 + \frac{1}{6}\vec{r}_i^{(3)}(t)\Delta^3 + O(\Delta^4) \\ + \vec{r}_i(t - \Delta) &= \vec{r}_i(t) - \vec{v}_i(t)\Delta + \frac{1}{2}\vec{a}_i(t)\Delta^2 - \frac{1}{6}\vec{r}_i^{(3)}(t)\Delta^3 + O(\Delta^4) \end{aligned}$$

---

$$\vec{r}_i(t + \Delta) + \vec{r}_i(t - \Delta) = 2\vec{r}_i(t) + \vec{a}_i(t)\Delta^2 + O(\Delta^4)$$

$$\therefore \vec{r}_i(t + \Delta) = 2\vec{r}_i(t) - \vec{r}_i(t - \Delta) + \vec{a}_i(t)\Delta^2 + O(\Delta^4)$$

To obtain velocities,

$$\begin{aligned} \vec{r}_i(t + \Delta) &= \vec{r}_i(t) + \vec{v}_i(t)\Delta + \frac{1}{2}\vec{a}_i(t)\Delta^2 + \frac{1}{6}\vec{r}_i^{(3)}(t)\Delta^3 + O(\Delta^4) \\ - \vec{r}_i(t - \Delta) &= \vec{r}_i(t) - \vec{v}_i(t)\Delta + \frac{1}{2}\vec{a}_i(t)\Delta^2 - \frac{1}{6}\vec{r}_i^{(3)}(t)\Delta^3 + O(\Delta^4) \end{aligned}$$

---

$$\vec{r}_i(t + \Delta) - \vec{r}_i(t - \Delta) = 2\vec{v}_i(t)\Delta + O(\Delta^3)$$

$$\therefore \vec{v}_i(t) = \frac{\vec{r}_i(t + \Delta) - \vec{r}_i(t - \Delta)}{2\Delta} + O(\Delta^2)$$

The above two results constitute the Verlet discretization scheme.

(Verlet discretization scheme)

$$\begin{cases} \vec{r}_i(t + \Delta) = 2\vec{r}_i(t) - \vec{r}_i(t - \Delta) + \vec{a}_i(t)\Delta^2 + O(\Delta^4) & (1) \\ \vec{v}_i(t) = \frac{\vec{r}_i(t + \Delta) - \vec{r}_i(t - \Delta)}{2\Delta} + O(\Delta^2) & (2) \end{cases}$$

The Verlet algorithm for MD integration is a straightforward application of these two equations.

(Verlet algorithm)

Given  $\vec{r}_i(t - \Delta)$  and  $\vec{r}_i(t)$ ,

1. Compute  $\vec{a}_i(t)$  as a function of  $\{\vec{r}_i(t)\}$ ,
2.  $\vec{r}_i(t + \Delta) \leftarrow 2\vec{r}_i(t) - \vec{r}_i(t - \Delta) + \vec{a}_i(t)\Delta^2$ ,

$$3. \quad \bar{v}_i(t) \leftarrow [\bar{r}_i(t+\Delta) - \bar{r}_i(t-\Delta)] / (2\Delta),$$

A problem of this discretization scheme is that the velocity at time  $t$  cannot be calculated until the coordinate at time  $t+\Delta$  is calculated. In the slight variation, called the velocity-Verlet scheme, of the above discretization scheme, we are given  $(\bar{r}_i(t), \bar{v}_i(t))$  and predict  $(\bar{r}_i(t+\Delta), \bar{v}_i(t+\Delta))$ .

### VELOCITY-VERLET DISCRETIZATION

(Theorem) The following algebraic equations give the same sequence of states,  $\bar{r}_i(n\Delta)$ , as that obtained by the Verlet discretization, Eq. (1).

$$\begin{cases} \bar{r}_i(t+\Delta) = \bar{r}_i(t) + \bar{v}_i(t)\Delta + \frac{1}{2}\bar{a}_i(t)\Delta^2 + O(\Delta^4) & (3) \\ \bar{v}_i(t+\Delta) = \bar{v}_i(t) + \frac{\bar{a}_i(t) + \bar{a}_i(t+\Delta)}{2}\Delta + O(\Delta^3) & (4) \end{cases}$$

(Proof)

1. Using Eq. (3) of the velocity-Verlet discretization scheme for two consecutive time steps,  $t$  and  $t+\Delta$ ,

$$\begin{aligned} \bar{r}_i(t+2\Delta) &= \bar{r}_i(t+\Delta) + \bar{v}_i(t+\Delta)\Delta + \frac{1}{2}\bar{a}_i(t+\Delta)\Delta^2 \\ - \quad \bar{r}_i(t+\Delta) &= \bar{r}_i(t) + \bar{v}_i(t)\Delta + \frac{1}{2}\bar{a}_i(t)\Delta^2 \\ \hline \bar{r}_i(t+2\Delta) - \bar{r}_i(t+\Delta) &= \bar{r}_i(t+\Delta) - \bar{r}_i(t) + [\bar{v}_i(t+\Delta) - \bar{v}_i(t)]\Delta + \frac{\bar{a}_i(t+\Delta) - \bar{a}_i(t)}{2}\Delta^2 \end{aligned}$$

Let us eliminate the velocities using Eq. (4),

$$\bar{r}_i(t+2\Delta) - \bar{r}_i(t+\Delta) = \bar{r}_i(t+\Delta) - \bar{r}_i(t) + \left[ \frac{\bar{a}_i(t+\Delta) + \bar{a}_i(t)}{2} \Delta \right] \Delta + \frac{\bar{a}_i(t+\Delta) - \bar{a}_i(t)}{2} \Delta^2$$

i.e.,

$$\begin{aligned} \bar{r}_i(t+2\Delta) - \bar{r}_i(t+\Delta) &= \bar{r}_i(t+\Delta) - \bar{r}_i(t) + \bar{a}_i(t+\Delta)\Delta^2 \\ \therefore \bar{r}_i(t+2\Delta) &= 2\bar{r}_i(t+\Delta) - \bar{r}_i(t) + \bar{a}_i(t+\Delta)\Delta^2 \end{aligned}$$

This is nothing but the Verlet rule, Eq. (1), applied to  $t+2\Delta$  instead of  $t+\Delta$ . We have thus derived the first equation of the Verlet scheme from the two equations in the velocity-Verlet scheme, i.e., the trajectory (or the time sequence of positions) generated by the two schemes is equivalent. Consequently, Eq. (3) has the same error bound as Eq. (1).

2. In the Verlet discretization scheme, the time sequence of positions, Eq. (1), is generated without the use of velocities. Optionally, velocities are estimated using Eq. (2) with  $O(\Delta^2)$  error. In the velocity-Verlet scheme, on the contrary, the time sequence of positions, Eq. (3), and that of velocities, Eq. (4), are generated together. Moreover, the velocity estimate, Eq. (4), has a smaller  $O(\Delta^3)$  error bound compared to that in Eq. (2). This is proven as follows.

Let us apply the velocity-Verlet position-update rule, Eq. (3), backward in time, so that the positions at time  $t$  are predicted from information at time  $t+\Delta$ :

$$\bar{r}_i(t) = \bar{r}_i(t+\Delta) - \bar{v}_i(t+\Delta)\Delta + \frac{1}{2}\bar{a}_i(t+\Delta)\Delta^2 + O(\Delta^4)$$

By adding the above equation and Eq. (3),

$$0 = [\bar{v}_i(t) - \bar{v}_i(t + \Delta)]\Delta + \frac{1}{2}[\bar{a}_i(t) + \bar{a}_i(t + \Delta)]\Delta^2 + O(\Delta^4)$$

By dividing the above equation by  $\Delta$  and solving it for  $\bar{v}_i(t + \Delta)$ , we obtain

$$\bar{v}_i(t + \Delta) = \bar{v}_i(t) + \frac{\Delta}{2}[\bar{a}_i(t) + \bar{a}_i(t + \Delta)] + O(\Delta^3) . //$$

## VELOCITY-VERLET ALGORITHM

For notational convenience, let's define

$$\bar{v}_i(t + \frac{\Delta}{2}) \equiv \bar{v}_i(t) + \frac{\Delta}{2}\bar{a}_i(t) . \quad (5)$$

Eqs. (3) and (4) are then rewritten as

$$\left\{ \begin{array}{l} \bar{r}_i(t + \Delta) = \bar{r}_i(t) + \bar{v}_i(t + \frac{\Delta}{2})\Delta \quad (6) \\ \bar{v}_i(t + \Delta) = \bar{v}_i(t + \frac{\Delta}{2}) + \frac{\Delta}{2}\bar{a}_i(t + \Delta) \quad (7) \end{array} \right.$$

The velocity-Verlet algorithm is just a re-statement of Eqs. (5)-(7).

(Velocity-Verlet algorithm)

Given  $(\bar{r}_i(t), \bar{v}_i(t))$ ,

1. Compute  $\bar{a}_i(t)$  as a function of  $\{\bar{r}_i(t)\}$ ,
2.  $\bar{v}_i(t + \frac{\Delta}{2}) \leftarrow \bar{v}_i(t) + \frac{\Delta}{2}\bar{a}_i(t)$ ,
3.  $\bar{r}_i(t + \Delta) \leftarrow \bar{r}_i(t) + \bar{v}_i(t + \frac{\Delta}{2})\Delta$ ,
4. Compute  $\bar{a}_i(t + \Delta)$  as a function of  $\{\bar{r}_i(t + \Delta)\}$ ,
5.  $\bar{v}_i(t + \Delta) \leftarrow \bar{v}_i(t + \frac{\Delta}{2}) + \frac{\Delta}{2}\bar{a}_i(t + \Delta)$

Computing  $\bar{a}_i(t)$  as a function of  $\{\bar{r}_i(t)\}$  is done in function `computeAccel()`. In the program, we perform an MD simulation for `StepLimit` steps, and `computeAccel()` is called `StepLimit+1` times.

(Velocity-Verlet algorithm for `StepLimit` steps)

Initialize  $(\bar{r}_i, \bar{v}_i)$  for all  $i$

Compute  $\bar{a}_i$  as a function of  $\{\bar{r}_i\}$  for all  $i$ —function `computeAccel()`

for `stepCount = 1 to StepLimit`

do the following—function `singleStep()`

$\bar{v}_i \leftarrow \bar{v}_i + \bar{a}_i\Delta / 2$  for all  $i$

$\bar{r}_i \leftarrow \bar{r}_i + \bar{v}_i\Delta$  for all  $i$

Compute  $\bar{a}_i$  as a function of  $\{\bar{r}_i\}$  for all  $i$ —function `computeAccel()`

$\bar{v}_i \leftarrow \bar{v}_i + \bar{a}_i\Delta / 2$  for all  $i$

endfor



Now we have learned the skeleton of `md.c` program. The next lecture will deal with some details of the program. These include:

- Periodic boundary conditions
  - Shifted potential
  - Energy conservation and temperature
  - Initialization: fcc lattice, random velocity
- \* The velocity-Verlet algorithm is more elegantly derived using a split-operator technique in the Ph.D. thesis by M. Tuckerman at Columbia University. See “Reversible multiple time scale molecular dynamics,” M. Tuckerman, B. J. Berne, and G. J. Martyna, *J. Chem. Phys.* **97**, 1990 (1992).

# Molecular Dynamics Basics II

## Periodic Boundary Conditions

(There are only two places you see this in the program)

This technique allows us to simulate bulk solid and liquid properties with a small number of atoms ( $N < 1,000$ ) by eliminating surface effects.

Note that for 1,000 atoms arranged in a  $10 \times 10 \times 10$  cube,

$$10^3 - 8^3 = 488 \text{ atoms}$$

(nearly half the atoms) are at the surface. Since these surface atoms are in very different environment from the bulk atoms, the average properties computed for this system are very different from bulk properties.

Periodic boundary conditions are implemented by replicating a simulation box of size  $L_x \times L_y \times L_z$  to form an infinite lattice. Note that we assume atoms to be contained in a rectangular simulation box.

`double Region[3]`: Three-element array containing the box lengths,  $L_x$ ,  $L_y$ , and  $L_z$ .

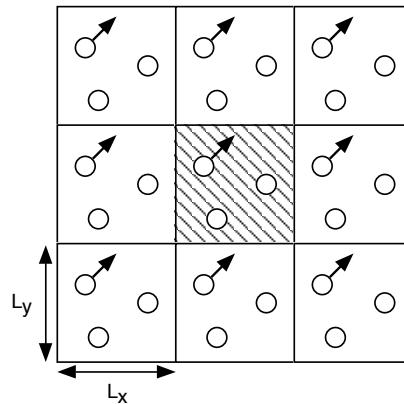

**Figure:** Periodically repeated images of an original simulation box (shaded) in 2 dimensions.

As an atom moves in the original simulation box, all the images move in a concerted manner by the same amount.

Since all the images are just shifted copies of an original atom, we need to keep only the coordinates of the original (central) image as a representative of all images. When an atom leaves the central box by crossing a boundary, attention is switched to the image just entering the central box.

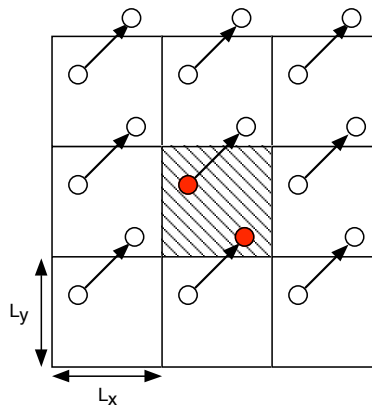

**Figure:** Change of the representative atom due to boundary crossing of the atom.

At every MD step, we enforce that an atomic coordinate satisfies

$$0 \leq x_i < L_x, 0 \leq y_i < L_y, 0 \leq z_i < L_z.$$

If  $\vec{r}_i(t)$  is in the central box and time increment  $\Delta$  is small,  $\vec{r}_i(t+\Delta)$  is at most in the neighbor image (if this assumption becomes invalid, then exceptions may occur during program execution):  $-L_x \leq x_i(t+\Delta) < 2L_x$ , etc. In this case, an atom can be “pulled back” to the central box by

$$\begin{cases} x_i \leftarrow x_i - \text{SignR}\left(\frac{L_x}{2}, x_i\right) - \text{SignR}\left(\frac{L_x}{2}, x_i - L_x\right) \\ y_i \leftarrow y_i - \text{SignR}\left(\frac{L_y}{2}, y_i\right) - \text{SignR}\left(\frac{L_y}{2}, y_i - L_y\right) \\ z_i \leftarrow z_i - \text{SignR}\left(\frac{L_z}{2}, z_i\right) - \text{SignR}\left(\frac{L_z}{2}, z_i - L_z\right) \end{cases}$$

where

$$\text{SignR}\left(\frac{L_x}{2}, x_i\right) = \begin{cases} \frac{L_x}{2} & x_i > 0 \\ -\frac{L_x}{2} & x_i \leq 0 \end{cases}$$

and this means

$$\begin{cases} L_x < x_i & x_i - \frac{L_x}{2} - \frac{L_x}{2} = x_i - L_x \\ 0 < x_i \leq L_x & x_i - \frac{L_x}{2} + \frac{L_x}{2} = x_i \\ x_i \leq 0 & x_i + \frac{L_x}{2} + \frac{L_x}{2} = x_i + L_x \end{cases}$$

double RegionH[3]: An array ( $L_x/2, L_y/2, L_z/2$ )

## Minimum Image Convention

In principle, an atom interacts with all the images of another atom (and even with its own images except for itself).

In practice, we make the simulation box larger enough so that  $u(r > L_x/2)$ , etc., can be neglected. Then an atom interacts with only the nearest image of another atom.

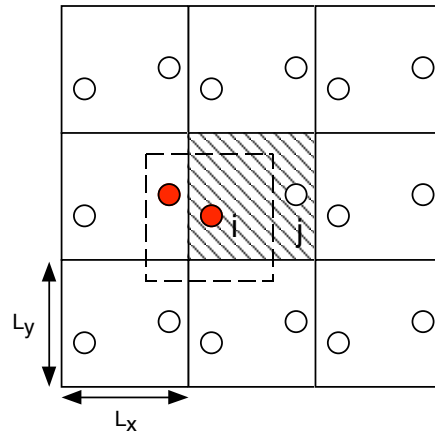

Or we can imagine a box of size  $L_x \times L_y \times L_z$  centered at atom  $i$ , and this atom interacts only with other atoms,  $j$ , in this imaginary box. Therefore,

$$\begin{cases} -\frac{L_x}{2} \leq x_{ij} < \frac{L_x}{2} \\ -\frac{L_y}{2} \leq y_{ij} < \frac{L_y}{2} \\ -\frac{L_z}{2} \leq z_{ij} < \frac{L_z}{2} \end{cases}$$

during the computation of forces, where  $\vec{r}_{ij} = \vec{r}_i - \vec{r}_j = (x_{ij}, y_{ij}, z_{ij})$ . In the program, this is achieved by

$$\begin{cases} x_{ij} \leftarrow x_{ij} - \text{SignR}\left(\frac{L_x}{2}, x_{ij} + \frac{L_x}{2}\right) - \text{SignR}\left(\frac{L_x}{2}, x_{ij} - \frac{L_x}{2}\right) \\ y_{ij} \leftarrow y_{ij} - \text{SignR}\left(\frac{L_y}{2}, y_{ij} + \frac{L_y}{2}\right) - \text{SignR}\left(\frac{L_y}{2}, y_{ij} - \frac{L_y}{2}\right) \\ z_{ij} \leftarrow z_{ij} - \text{SignR}\left(\frac{L_z}{2}, z_{ij} + \frac{L_z}{2}\right) - \text{SignR}\left(\frac{L_z}{2}, z_{ij} - \frac{L_z}{2}\right) \end{cases}$$

### Shifted Potential

With the minimal image convention, interatomic interaction is cut-off at half the box length. If the box is not large enough, this truncation causes a significant discontinuity in the potential function and our derivation of forces breaks down (we cannot differentiate the potential).

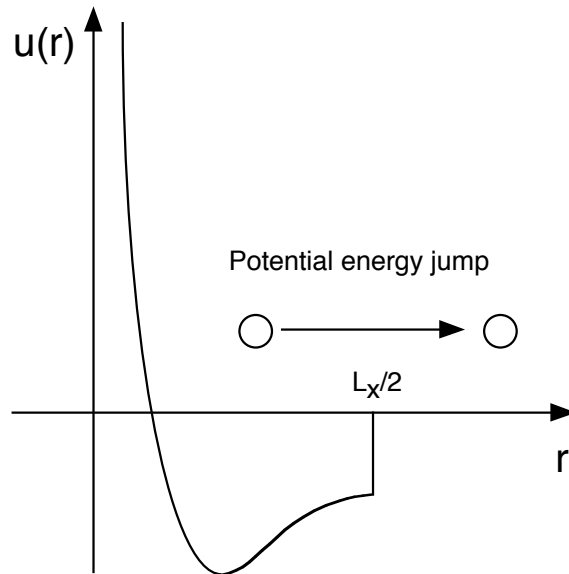

To remedy this, we introduce a cut-off length  $r_c < L_x/2$ , etc., and modify the potential such that both  $u(r)$  and  $du/dr$  are continuous at  $r_c$ .

$$u'(r) = \begin{cases} u(r) - u(r_c) - (r - r_c) \frac{du}{dr} \Big|_{r=r_c} & r < r_c \\ 0 & r \geq r_c \end{cases}$$

For the Lennard-Jones potential,  $r_c = 2.5\sigma$  is conventionally used. This causes some shift in the potential minimum but little shift in the minimum position.

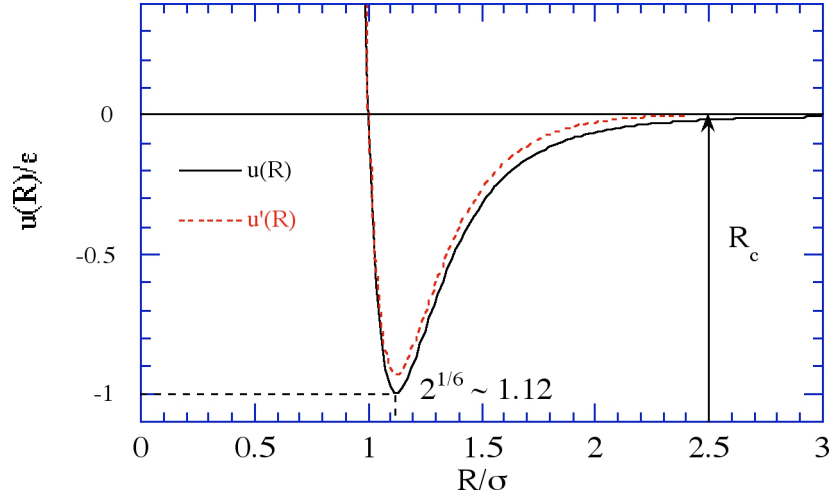

**Figure:** Truncated Lennard-Jones potential.

## Energy

In addition to the potential energy,  $V$ , introduced before, we introduce the kinetic energy,  $K$ , and the total energy,  $E$ , as a sum of both.

$$\begin{aligned} E &= K + V \\ &= \sum_{i=0}^{N-1} \frac{m}{2} |\dot{\vec{r}}_i|^2 + \sum_{i < j} u(r_{ij}) \end{aligned}$$

where

$$|\dot{\vec{r}}_i|^2 = \dot{x}_i^2 + \dot{y}_i^2 + \dot{z}_i^2 .$$

## ENERGY CONSERVATION

We can prove that the total energy,  $E$ , does not change in time, if Newton's equation is exactly integrated.

In order to prove the energy conservation, let's consider

$$\begin{aligned} \dot{E} &= \dot{K} + \dot{V} \\ &= \sum_{i=0}^{N-1} \frac{m}{2} \frac{d}{dt} (\dot{x}_i^2 + \dot{y}_i^2 + \dot{z}_i^2) + \sum_{i=0}^{N-1} \left( \frac{dx_i}{dt} \frac{\partial V}{\partial x_i} + \frac{dy_i}{dt} \frac{\partial V}{\partial y_i} + \frac{dz_i}{dt} \frac{\partial V}{\partial z_i} \right) \\ &= \sum_{i=0}^{N-1} \frac{m}{2} 2 (\dot{x}_i \ddot{x}_i + \dot{y}_i \ddot{y}_i + \dot{z}_i \ddot{z}_i) + \sum_{i=0}^{N-1} \left( \dot{x}_i \frac{\partial V}{\partial x_i} + \dot{y}_i \frac{\partial V}{\partial y_i} + \dot{z}_i \frac{\partial V}{\partial z_i} \right) \\ &= \sum_{i=0}^{N-1} m \dot{\vec{r}}_i \cdot \ddot{\vec{r}}_i + \sum_{i=0}^{N-1} \dot{\vec{r}}_i \cdot \frac{\partial V}{\partial \vec{r}_i} \\ &= \sum_{i=0}^{N-1} \dot{\vec{r}}_i \cdot (m \ddot{\vec{r}}_i - \vec{F}_i) \end{aligned}$$

From Newton's equation, the last expression is zero.

In the derivation, vector inner product is defined as

$$\vec{a} \cdot \vec{b} = (a_x, a_y, a_z) \cdot (b_x, b_y, b_z) = a_x b_x + a_y b_y + a_z b_z$$

and note that

$$\frac{d}{dt}(fg) = \dot{f}g + f\dot{g}.$$

With discretization approximation, the total energy is not rigorously conserved anymore. How well the total energy is conserved is a good measure for how small  $\Delta$  we should use.

$\Delta = 0.005$  in the normalized unit is typically used for the Lennard-Jones potential (see the figure below).

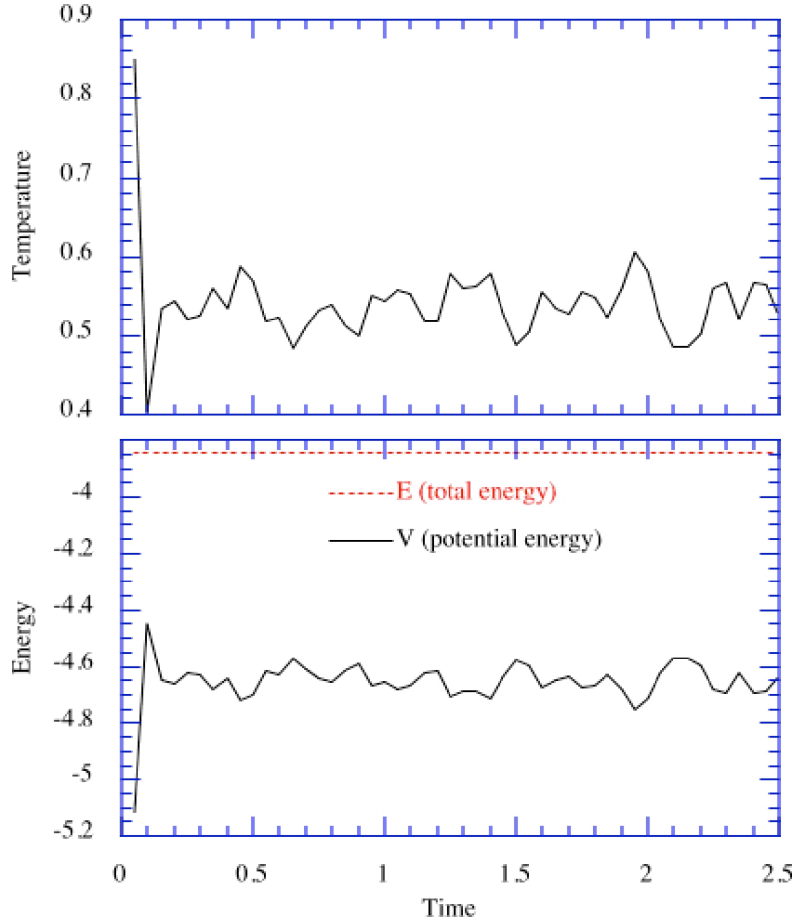

## Temperature

Temperature,  $T$ , is related to the kinetic energy as follows:

$$\frac{3Nk_B T}{2} = \sum_{i=0}^{N-1} \frac{m}{2} \left| \dot{\vec{r}}_i \right|^2,$$

where

$k_B = 1.38062 \times 10^{-16}$  erg/Kelvin— Boltzmann constant

By using the normalized coordinates,

$$\frac{3Nk_B T}{2} = m\sigma^2 \cdot \frac{\epsilon}{\sigma^2 m} \sum_{i=0}^{N-1} \frac{m}{2} \left| \dot{\vec{r}}_i' \right|^2$$

$$\therefore \frac{T}{\epsilon / k_B} = \frac{1}{3N} \sum_{i=0}^{N-1} \left| \dot{\vec{r}}_i' \right|^2$$

where  $\epsilon/k_B = 120$  Kelvin is the Lennard-Jones temperature unit. Thus the average temperature 0.5 means  $60 \text{ K} \ll 273 \text{ K} = 0^\circ\text{C}$ .

## Initialization

The program starts to initialize the coordinates and velocities of all atoms.

### FACE CENTERED CUBIC (FCC) LATTICE

Atoms are initially arranged to form a regular lattice. Namely they occupy all the corners and face centers of a cube called a unit cell.

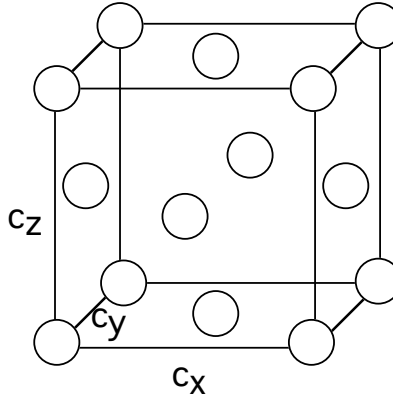

`double gap[3]:` ( $c_x, c_y, c_z$ ), the edge lengths of the unit cell

Since our unit cell is cubic,  $c_x = c_y = c_z = c$ .

Each unit cell contains

$$\frac{1}{8} \times 8(\text{corners}) + \frac{1}{2} \times 6(\text{faces}) = 4 \text{ atoms},$$

and the number density of atoms is given by  $\rho = 4 / c^3$ , or

$$c = (4 / \rho)^{1/3}.$$

The four coordinates are given (in unit of  $c$ ) as:  $(0, 0, 0)$ ,  $(0, 1/2, 1/2)$ ,  $(1/2, 0, 1/2)$ ,  $(1/2, 1/2, 0)$ . These four coordinates are stored in

`double origAtom[4][3]`

The simulated system is constructed by repeating the unit cells.

`int InitUcell[3]:` Stores the number of unit cells in the  $x$ ,  $y$ , and  $z$  directions

The total number of atoms is therefore given by

$$N = 4 \times \text{InitUcell}[0] \times \text{InitUcell}[1] \times \text{InitUcell}[2]$$

### RANDOM VELOCITY

We generate random velocities of magnitude

$$\frac{v_0^2}{3} = T_{init} \Rightarrow v_0 = \sqrt{3T_{init}}$$

`double InitTemp:` Initial temperature

For each atom, the velocity vector is then given by

$$\vec{v}_i = v_0 (\xi_0, \xi_1, \xi_2) = v_0 \vec{\xi}$$

where  $\vec{\xi}$  is a randomly oriented vector of unit length.

### RANDOM POINT IN A UNIT CIRCLE

The question is how to randomly generate a point on a unit sphere. We first start from a simpler problem, random point in a unit circle.

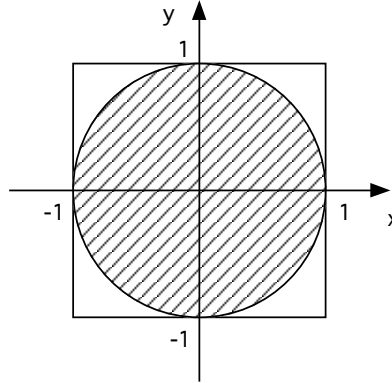

(Algorithm)

Let  $\text{rand}()$  be a uniform random-number generator in the range  $[0, 1]$

1.  $\zeta_i = 2 * \text{rand}() - 1$  ( $i = 0, 1$ ) so that  $-1 \leq \zeta_i < 1$
2.  $s^2 = \zeta_0^2 + \zeta_1^2$
3. if  $s^2 < 1$ , accept  $\vec{\zeta} = (\zeta_0, \zeta_1)$
4. else reject and go to 1

(Probability distribution)

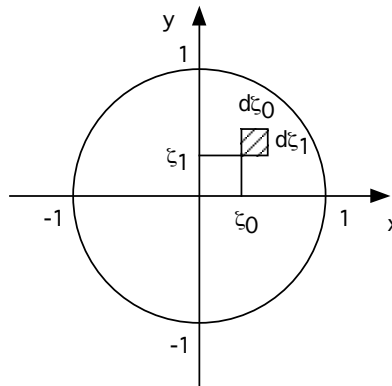

Probability to find a point in the shaded area

$$= (\# \text{ of points in the shaded area}) / (\text{total } \# \text{ of generated points})$$

$$= P(\zeta_0, \zeta_1) d\zeta_0 d\zeta_1$$

$$= (d\zeta_0 d\zeta_1 \sim \text{shaded area}) / (\pi \cdot 1^2 \sim \text{area of unit circle}), \text{ if there is no bias}$$

$$\therefore P(\zeta_0, \zeta_1) = 1 / \pi$$

(Polar coordinate system)

$$(\zeta_0, \zeta_1) = (s \cos \varphi, s \sin \varphi) \quad 0 \leq s < 1; 0 \leq \varphi < 2\pi$$



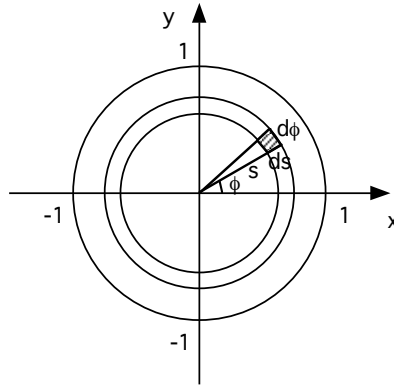

Again the probability density is given by the ratio of the shaded area divided by the total circular area.

$$P(s, \varphi) ds d\varphi = \frac{ds \cdot s d\varphi}{\pi \cdot 1^2} \text{ (if uniform)}$$

$$\therefore P(s, \varphi) = \frac{s}{\pi} \quad (1)$$

### RANDOM POINT ON A UNIT SPHERE

The above distribution is closely related to the uniform distribution on a unit sphere.  
(Spherical coordinate)

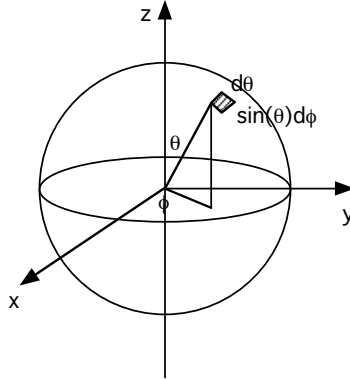

$$(\xi_0, \xi_1, \xi_2) = (\sin \theta \cos \varphi, \sin \theta \sin \varphi, \cos \theta) \quad 0 \leq \theta < \pi, 0 \leq \varphi < 2\pi$$

(Probability distribution)

$$P(\theta, \varphi) d\theta d\varphi = \frac{d\theta \cdot \sin \theta d\varphi}{4\pi \cdot 1^2}$$

$$\therefore P(\theta, \varphi) = \frac{\sin \theta}{4\pi} \quad (2)$$

If we identify  $s = \sin \frac{\theta}{2}$ , Eqs. (1) and (2) are equivalent.

$$\because 0 \leq \theta < \pi \Leftrightarrow 0 \leq \frac{\theta}{2} < \frac{\pi}{2} \Leftrightarrow 0 \leq s = \sin \frac{\theta}{2} < 1$$

$$\frac{s ds d\varphi}{\pi} = \frac{\sin \frac{\theta}{2} \frac{ds}{d\theta} d\theta d\varphi}{\pi} = \frac{\sin \frac{\theta}{2} \left( \frac{1}{2} \cos \frac{\theta}{2} \right) d\theta d\varphi}{\pi} = \frac{2 \sin \frac{\theta}{2} \cos \frac{\theta}{2} d\theta d\varphi}{4\pi} = \frac{\sin \theta d\theta d\varphi}{4\pi} //$$

Note that

$$\begin{cases} \xi_0 = \sin \theta \cos \varphi = 2 \sin \frac{\theta}{2} \cos \frac{\theta}{2} \cos \varphi = 2s\sqrt{1-s^2} \frac{\xi_0}{s} = 2\sqrt{1-s^2} \xi_0 \\ \xi_1 = \sin \theta \sin \varphi = 2 \sin \frac{\theta}{2} \cos \frac{\theta}{2} \sin \varphi = 2s\sqrt{1-s^2} \frac{\xi_1}{s} = 2\sqrt{1-s^2} \xi_1 \\ \xi_2 = \cos \theta = 1 - 2 \sin^2 \frac{\theta}{2} = 1 - 2s^2 \end{cases}$$

(Algorithm—Generating random points on a unit sphere)

Let  $\text{rand}()$  be a uniform random-number generator in the range  $[0, 1]$

1.  $\xi_i = 2 * \text{rand}() - 1$  ( $i = 0, 1$ ) so that  $-1 \leq \xi_i < 1$
2.  $s^2 = \xi_0^2 + \xi_1^2$
3. if  $s^2 < 1$ , accept  $(\xi_0, \xi_1, \xi_2) = (2\sqrt{1-s^2}\xi_0, 2\sqrt{1-s^2}\xi_1, 1-2s^2)$
4. else reject and go to 1

## LINEAR CONGRUENTIAL RANDOM NUMBER GENERATOR

Sequence of seemingly random integers between 1 and  $m-1$  is obtained by starting from some nonzero  $I_1$  and

$$I_{j+1} = aI_j \pmod{m}$$

We choose

$$m = 2^{31} - 1 = 2147483647$$

$$a = 16807$$

Uniform random number in the range  $[0, 1]$  is obtained as

$$r_j = I_j / m.$$

## References

1. M. P. Allen and D. J. Tildesley, *Computer Simulation of Liquids* (Oxford U. Press, Oxford, 1987).
2. D.C. Rapaport, *The Art of Molecular Dynamics Simulation, 2nd Ed.* (Cambridge Univ. Press, Cambridge, 2004).
3. D. Frenkel and B. Smit, *Understanding Molecular Simulation, 2nd Ed.* (Academic Press, New York, 2001).